



Quantum Information: from notebook, to lab bench, to market...

Jonathan L. Habif

Experimental Physicist & Research Lead

University of Southern California – ISI

890 Winter St., Waltham, MA

jhabif@isi.edu

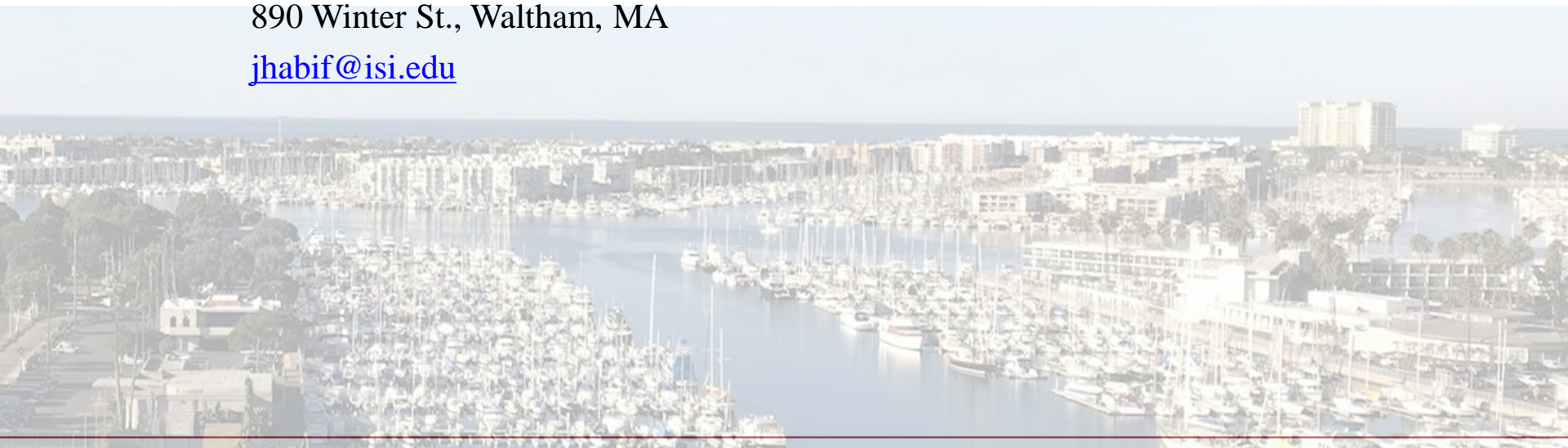

Advertisement for our new 'QuantumLA' Center



- **We are assembling a consortium of partners in the greater Los Angeles area, united with the common goal of designing, building, demonstrating and applying quantum information systems**
- **USC (led by Prof. Todd Brun), UCLA, Caltech, Chapman, UC Riverside, many others**
- **We are looking for partners to join our team, interested in all aspects of the “problem” – From Students to End Users!**
- **Come talk to me!**



Toward Quantum Coherent Technologies

The second quantum revolution is unfolding globally...

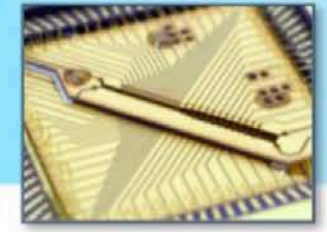
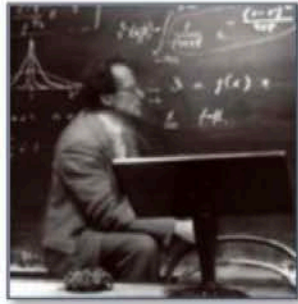

First quantum revolution

- Discovery of fundamental laws of the microscopic realm
- Formulation of quantum mechanics

'Bulk' quantum technologies

- Based on bulk effects, where many quantum degrees of freedom are manipulated at once
- Development of groundbreaking technologies such as transistor and laser

Second quantum revolution

- Technologies based on the manipulation of individual quantum states
- Make use of "strange" quantum properties, such as superposition and entanglement
- Secure communications, ultimate computing power, ultraprecise sensors

*Itay Hen, USC - ISI

A Brief (subjective and incomplete) History of Quantum Information Technologies

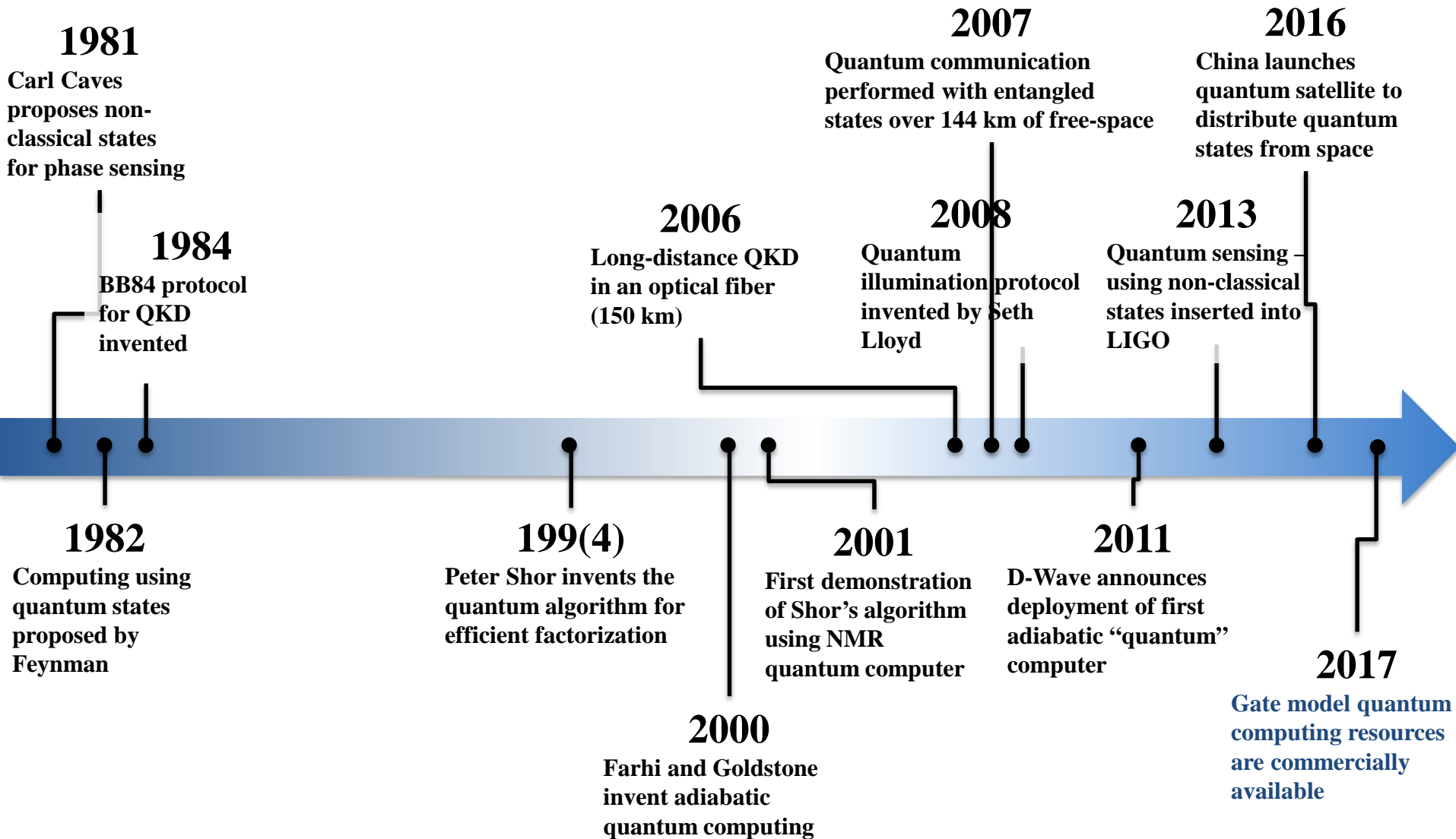



And in January 2018...

...the Chinese published a demonstration of a fully operational, global quantum network

PHYSICAL REVIEW LETTERS 120, 030501 (2018)

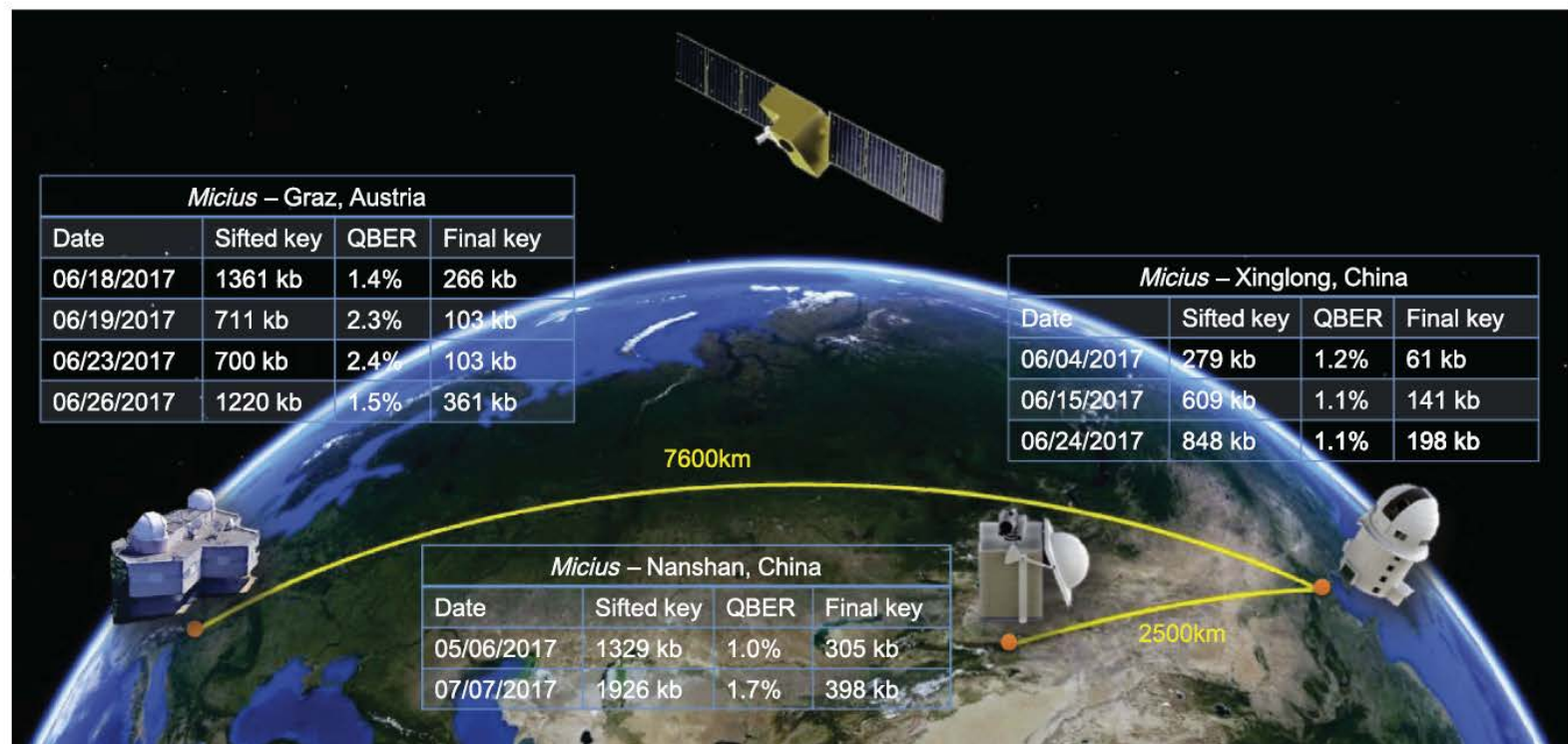

FIG. 1. Illustration of the three cooperating ground stations (Graz, Nanshan, and Xinglong). Listed are all paths used for key generation and the corresponding final key length.

Major Takeaways



- **Quantum Information Systems are NOW “System Problems” – need to be addressed by large team of scientists, engineers, managers – there’s a role for everyone**
- **Designing QIS will certainly uncover the most difficult scientific and engineering challenges – are there ways around them, or do we have to plow through them?**
- **This is an optical society meeting...where does optics fit into all of this?**

A Quantum Information System Development Team

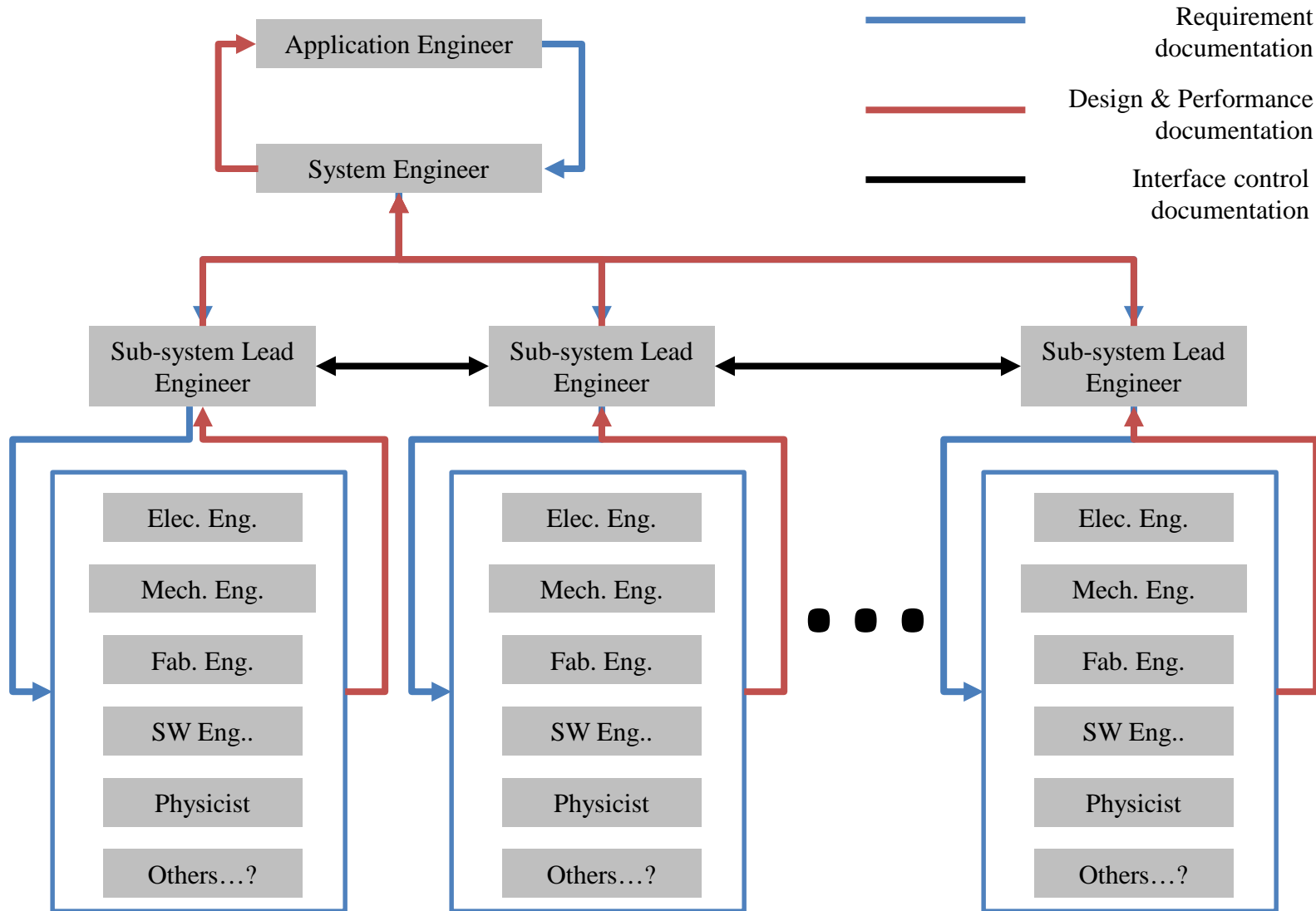

The Vision: A Global Quantum Information Grid

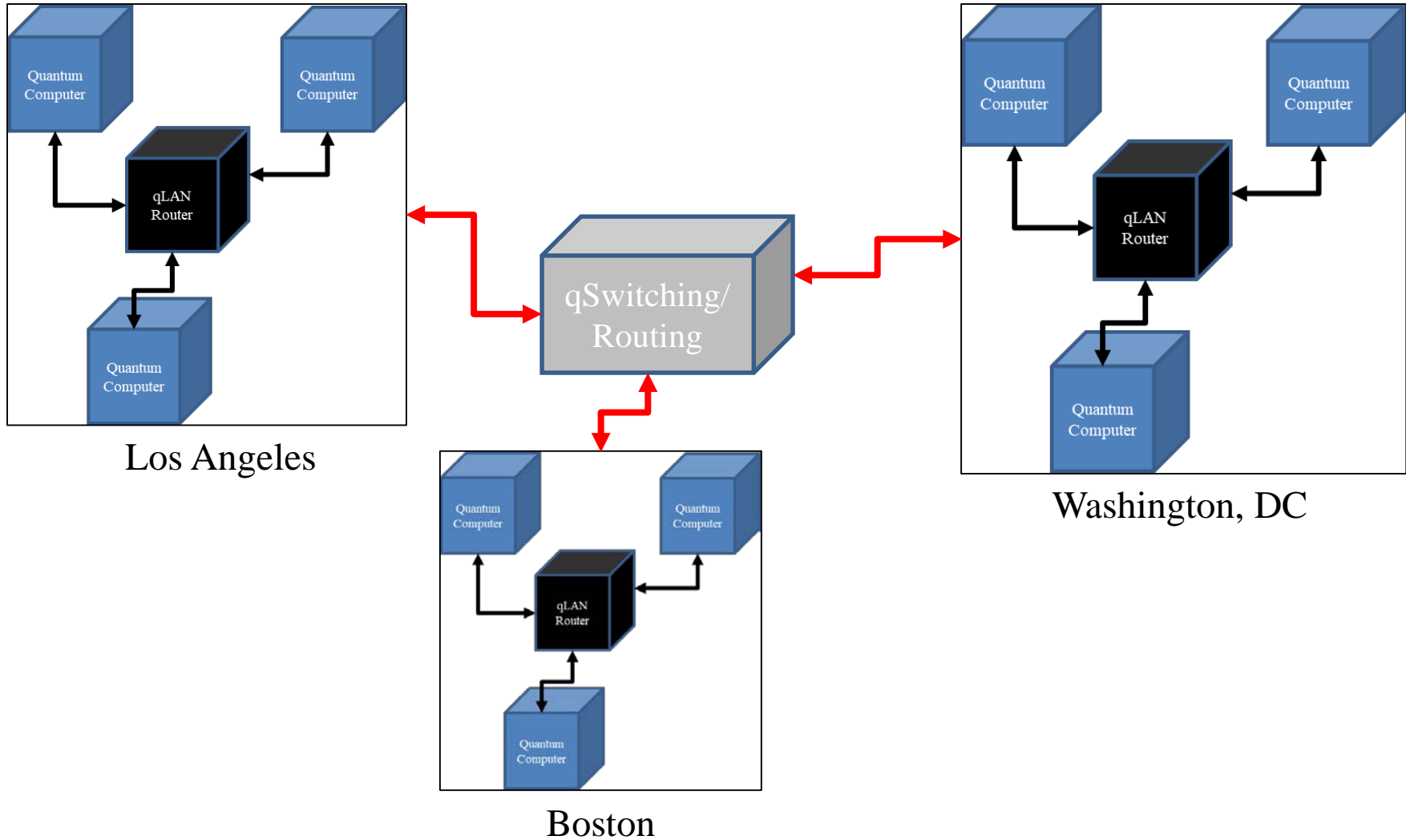

A Quantum Data Center



What will these machines look like?

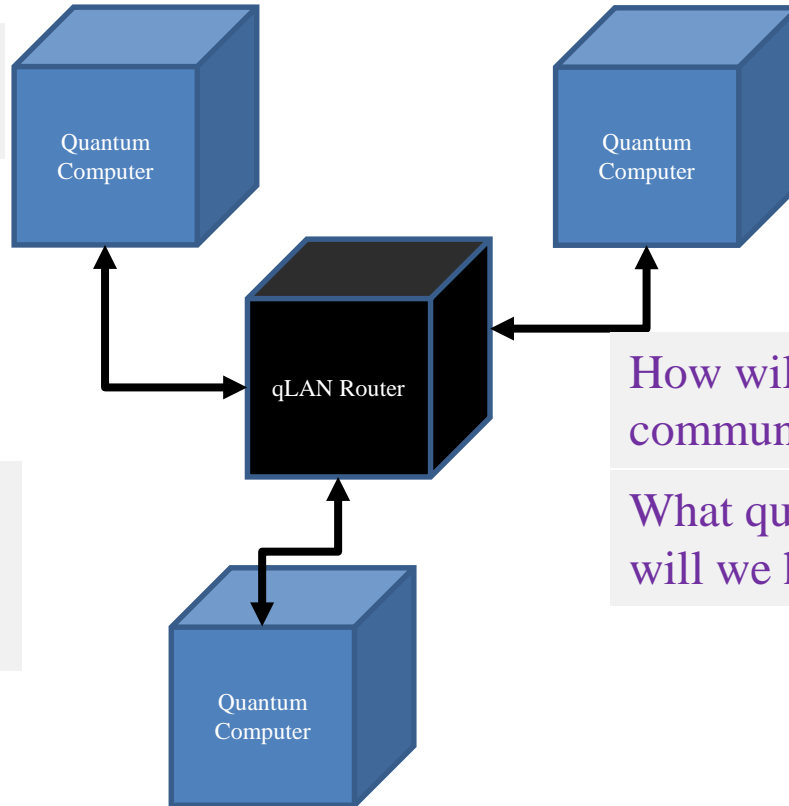

What will they be used for?
Who will have access to them?

How will these machines communicate?

What quantum data rate will we have?



QUANTUM COMPUTING

Building a Quantum Computer



- **First you need to pick an implementation:**
 - Superconducting circuits
 - Trapped Ions (or neutral atoms)
 - Semiconductor quantum dots
 - Optics!! (J. O’Brien, O. Pfister, A. Furusawa,
- **Next we need quantum coherent:**
 - State preparation
 - State control
 - State readout
- **Finally we need:**
 - An architecture that will scale to millions (probably billions) of qubit devices
 - A method to detect and correct errors (quantum error correction)
 - A good reason to build it!

Quantum Computing Applications



- ❑ QC is the road to
 - ❑ Secure communications.
 - ❑ RSA breaking.
 - ❑ Better materials through quantum chemistry.
 - ❑ Accelerated machine learning.
 - ❑ Combinatorial optimization.
- ❑ “What else?” is one of the big questions we (and everyone else) are trying to answer.

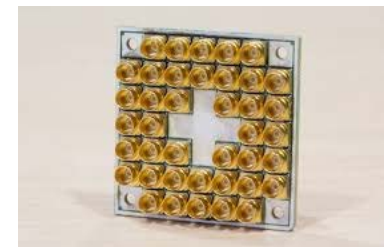
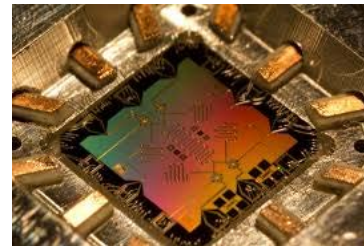
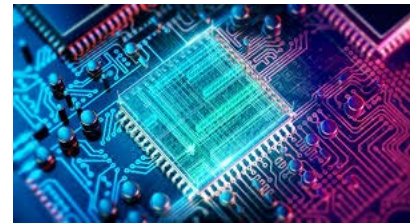

*Itay Hen, USC - ISI

Building a Quantum Computer

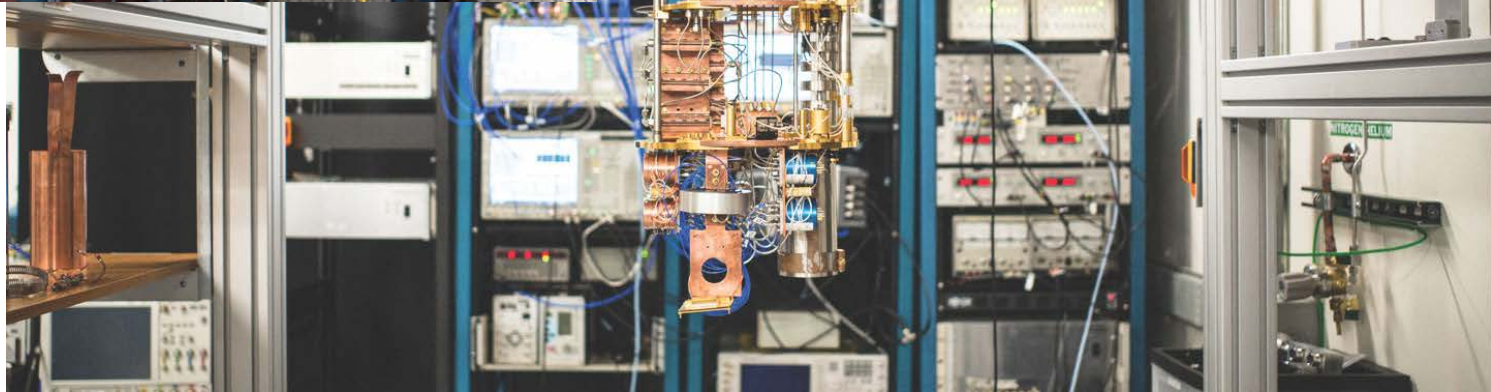
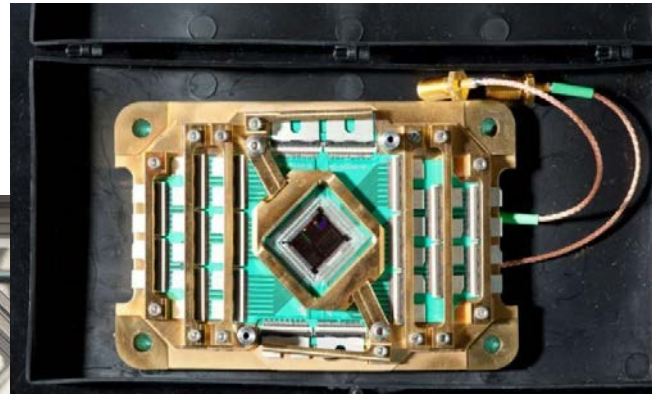
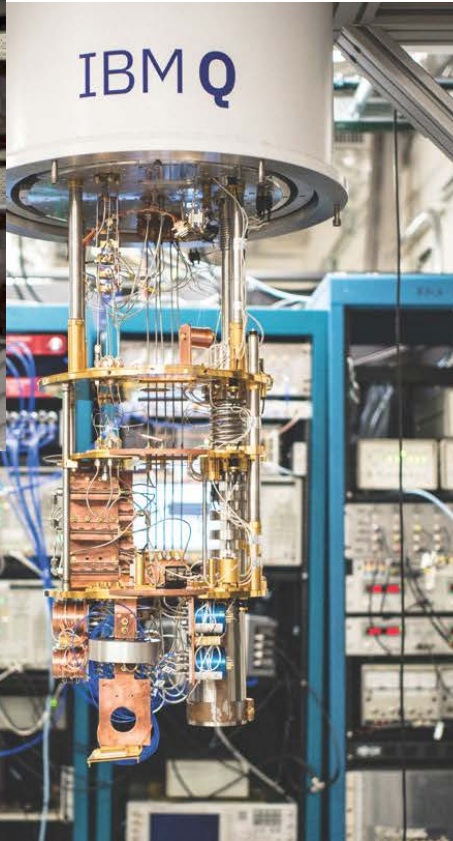
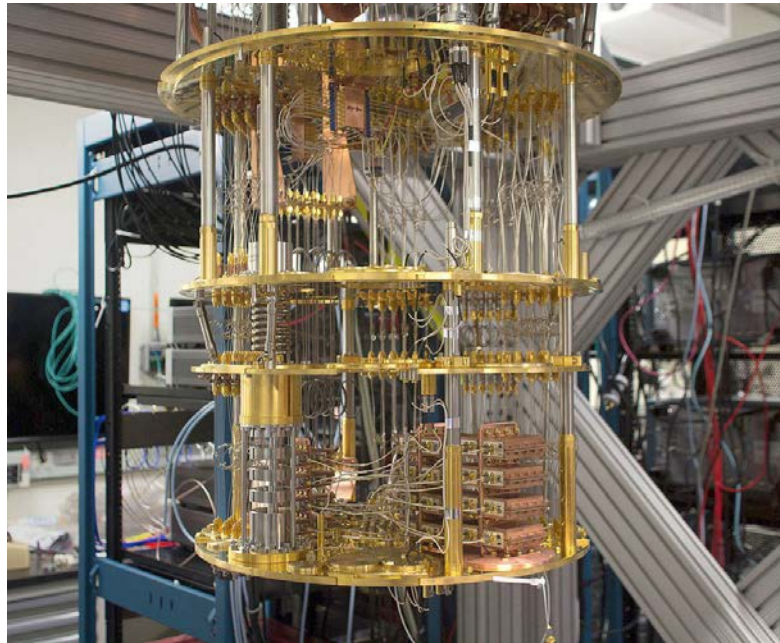



- If you need access to a (small-ish) quantum computer, you can get it NOW!

Quantum Annealing Machine

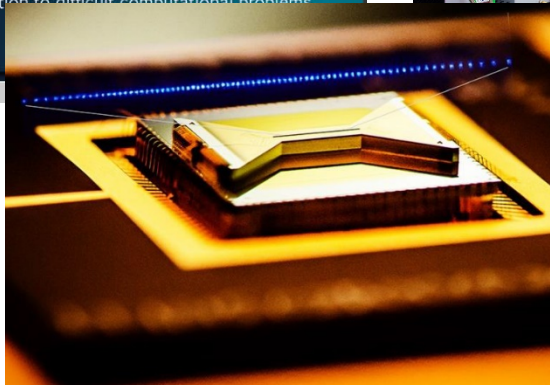
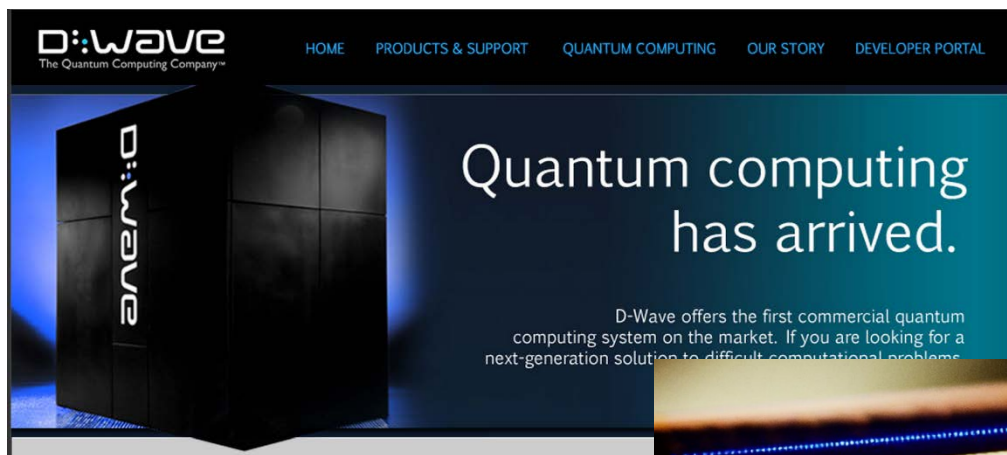

Superconducting QC



Trapped ion QC



Trapped Ion QC

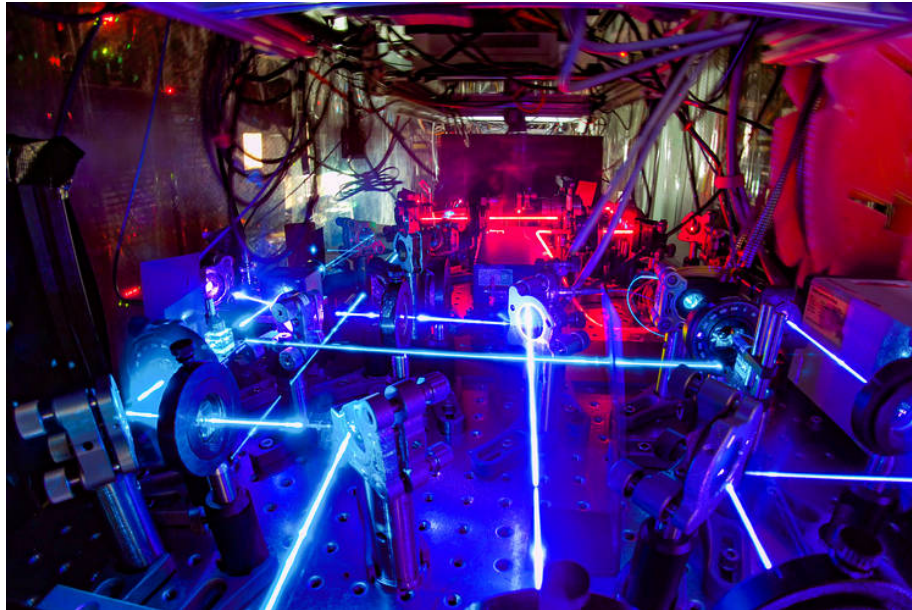

<https://blogs.wsj.com/cio/2017/07/26/startups-trapped-ions-could-lead-to-better-quantum-performance/>

Superconducting QC

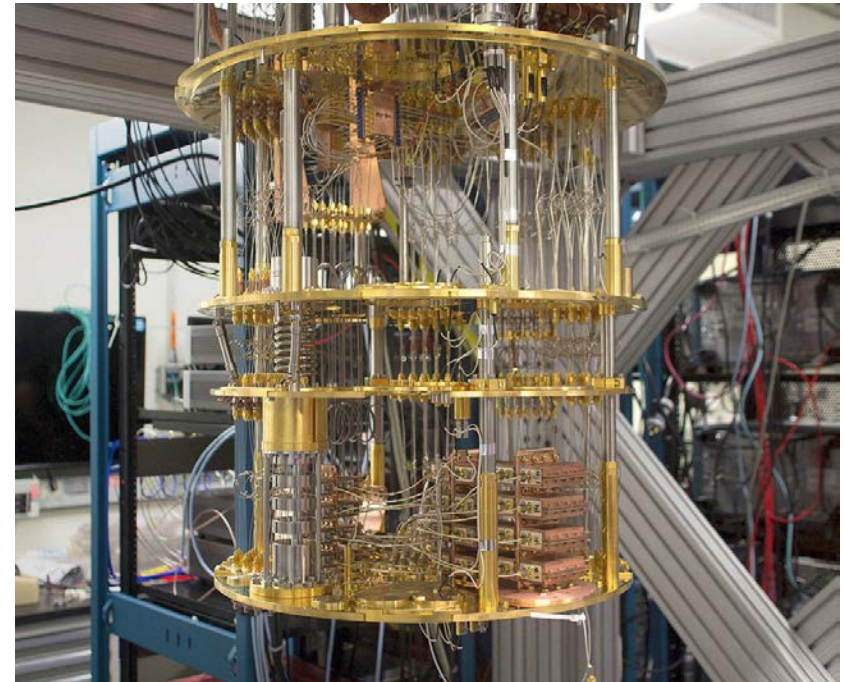

Engineering: *“How do we take these systems and scale them towards millions/billions of qubits? Transitions integrated technologies to these experimental platforms”*



Connecting quantum coherent processors

QUANTUM COMMUNICATIONS

Building a Quantum Communications Network



- **Quantum Key Distribution**
- **Networking Quantum Computers**
- **Distributed Quantum Sensing Applications**
- **Goal:** *“To distribute arbitrary quantum states over arbitrarily long distances, at arbitrarily high quantum data rates”*

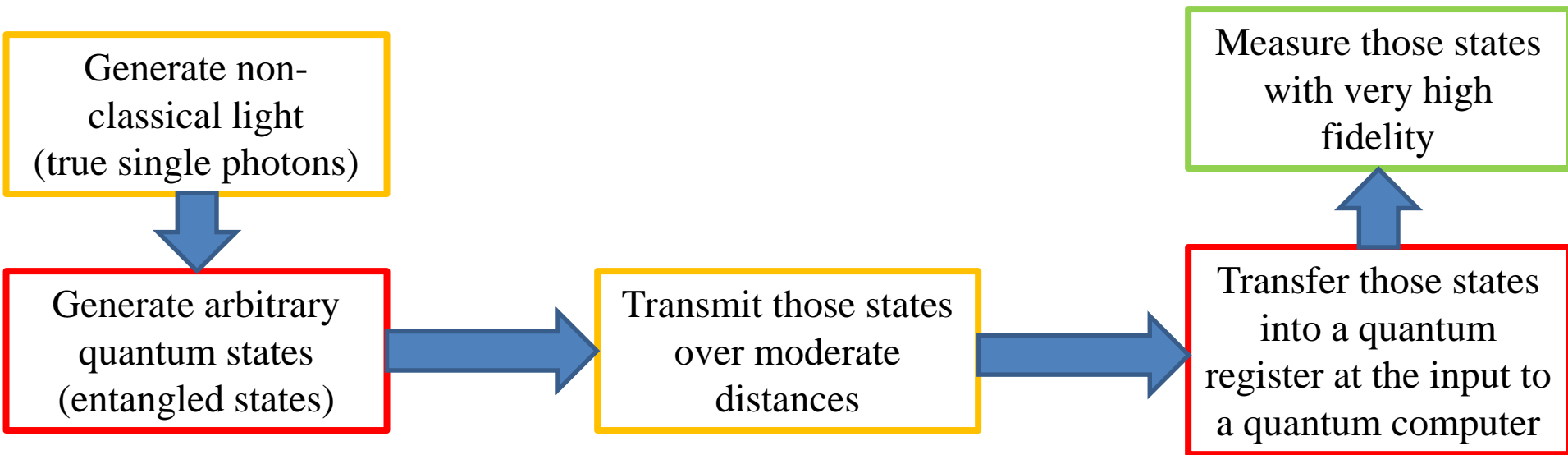



- **Research:** *“How do we make highly pure non-classical states for quantum information applications?”*

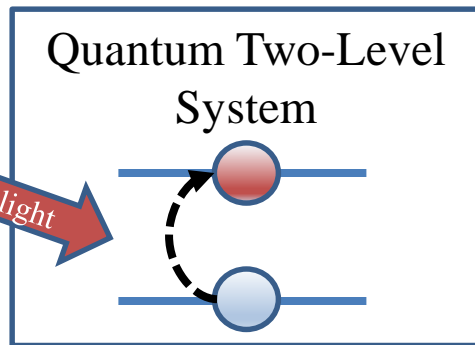

Single photons

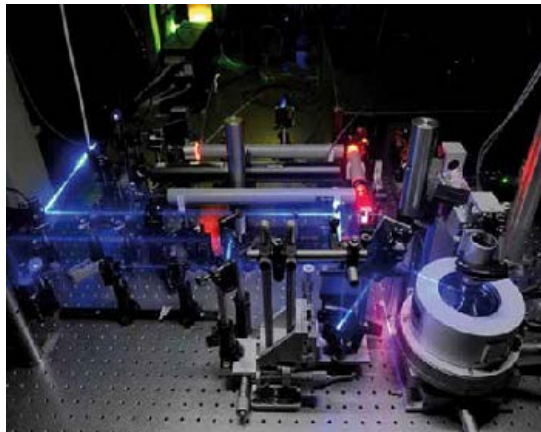
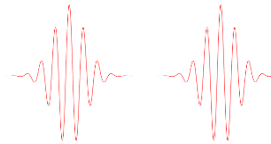

npj | Quantum Information

www.nature.com/npjqi

ARTICLE OPEN

Quantum dot single-photon sources with ultra-low multi-photon probability

Lukas Hanschke¹, Kevin A. Fischer², Stefan Appel¹, Danil Lukin², Jakob Wierzbowski¹, Shuo Sun², Rahul Trivedi², Jelena Vučković², Jonathan J. Finley² and Kai Müller¹

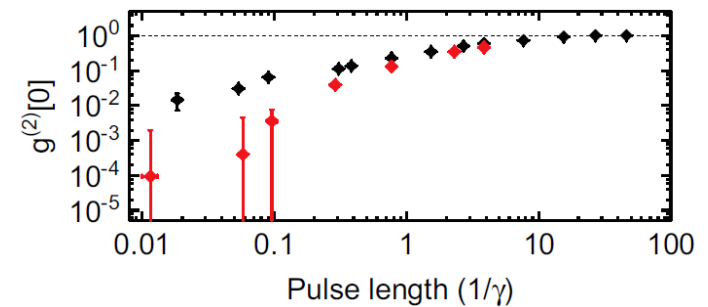

- How do we make systems like this scalable – huge arrays in a compact and addressable package?

<https://andor.oxinst.com/learning/view/article/semiconductor-structures>



- **Engineering:** *“How do we make sources of non-classical light that can be integrated and scaled?”*

QUANTUM MATERIALS

GaAs/InGaAs Quantum Dots

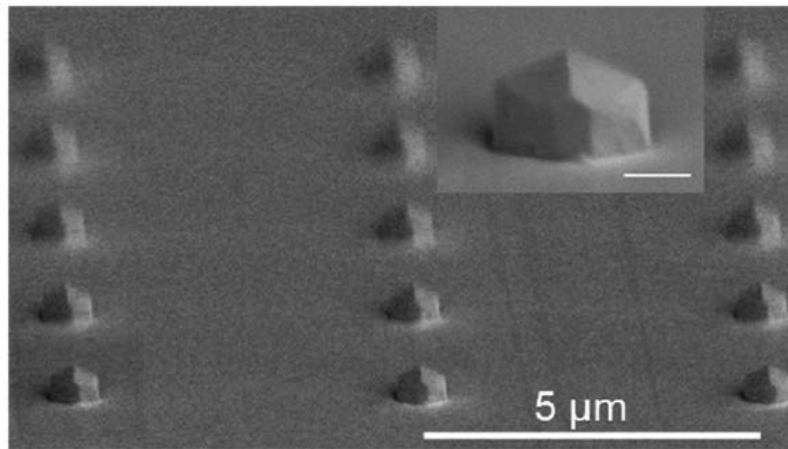

Madhukar group at USC

Nitrogen Vacancy Centers in Diamond

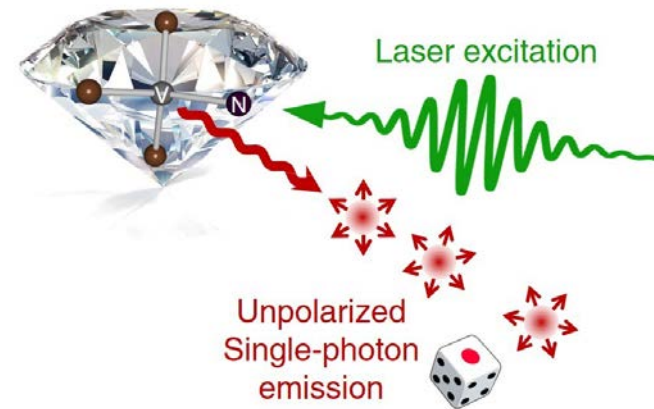

<https://phys.org/news/2017-05-unpolarized-single-photon-true-randomness-diamond.html>



Quantum Communications (Generating non-classical light)

- **Deployment:** *“How do we make sources of non-classical light that can be provided as a profitable, robust commercial product?”*

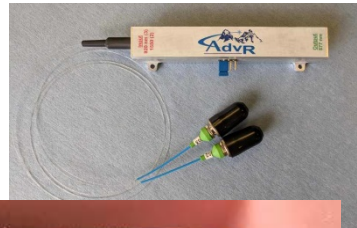

A fiber-coupled crystal that turns laser light into a maximally entangled quantum state!

$$|\psi_{SI}\rangle = \sum_{n=0}^{\infty} \sqrt{\frac{\bar{n}^n}{(1 + \bar{n})^{1+n}}} |n_s\rangle |n_l\rangle$$

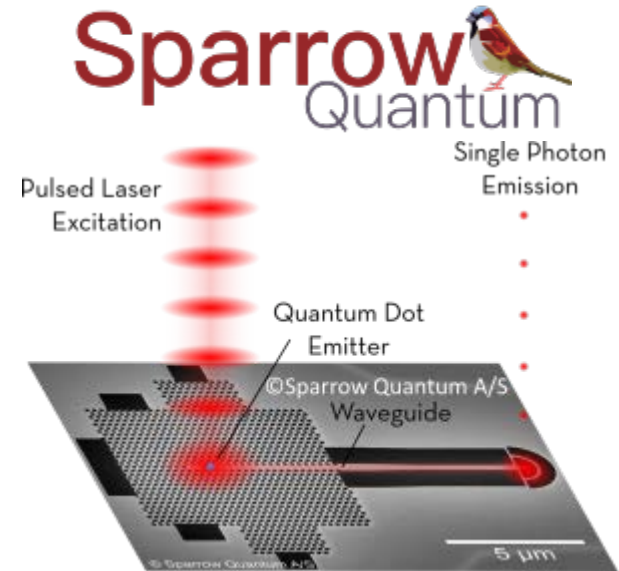

(also idQuantique)

An artificial quantum system that turns laser light into a single photon!

$$|\psi_{FOCK}\rangle = |n\rangle$$



Quantum Communications (Generating arbitrary quantum states)

- **Engineering:** *“How do we make linear and nonlinear optical circuits that takes non-classical light and makes arbitrary non-classical states?”*

Silicon Photonics

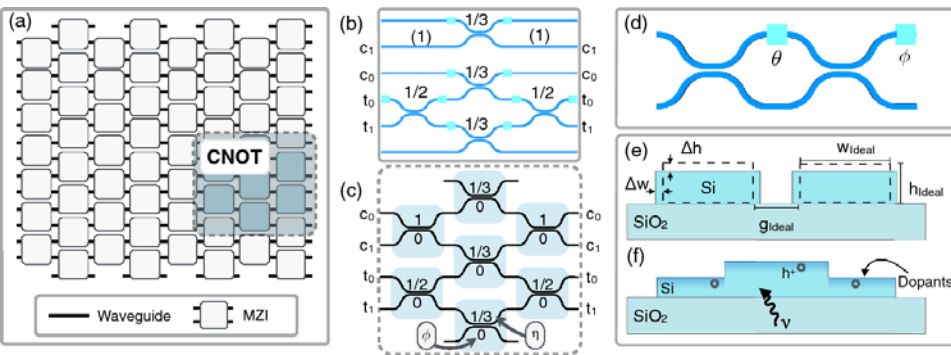

Dirk Englund group at MIT

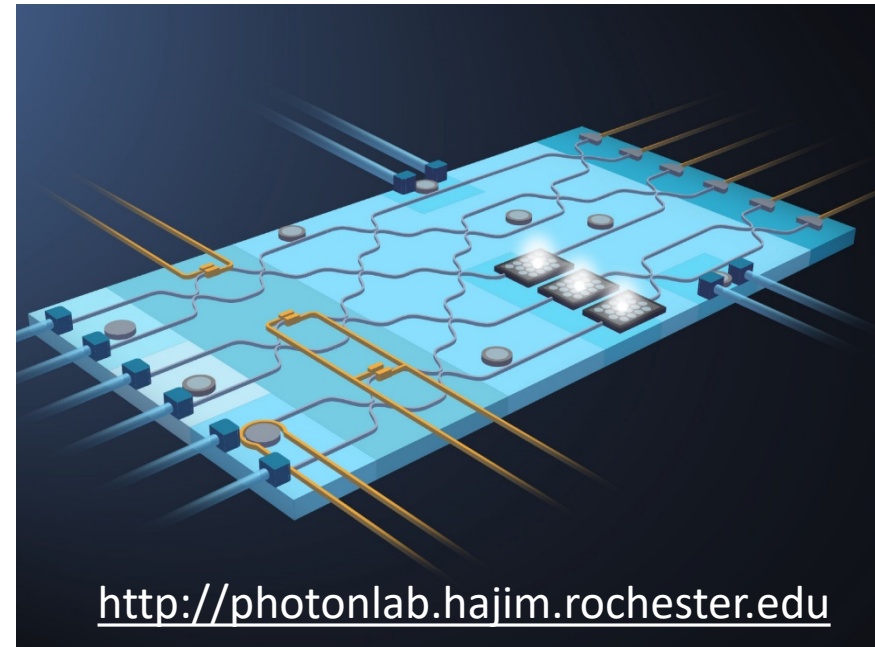



Quantum Communications (Transfer to quantum registers)

- **Research:** *“Qubits used for communications are at 200 THz, qubits used for computing are at 10 GHz...how do we get quantum data into and out of quantum computers?”*

Quantum coherent interaction between light, acoustics and electrons!

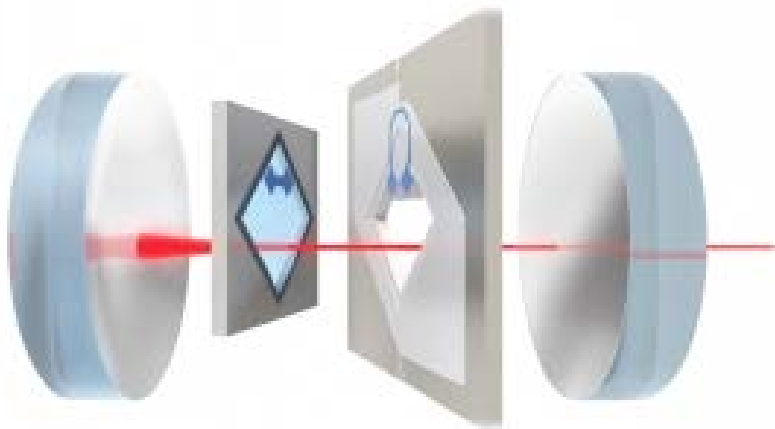

Konrad Lehnert group at CU - Boulder

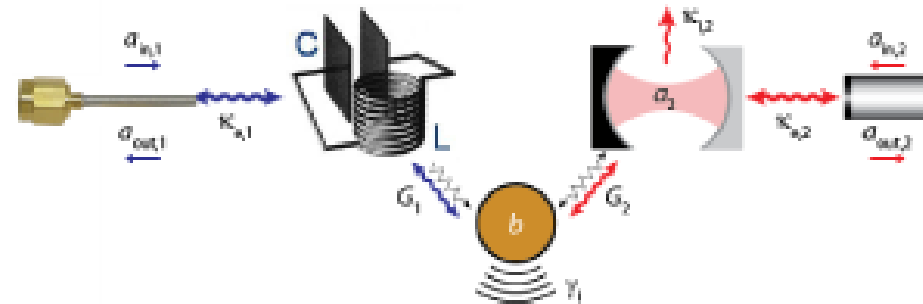

Oskar Painter group at CalTech

<https://jila.colorado.edu/lehnert/research/muri-wiring-quantum-networks-mechanical-transducers>

http://copilot.caltech.edu/research/SC_circuits



- **Deployment:** superconducting single photon detectors are now commercially available! They offer high count-rates, high quantum efficiency and very low noise all in a table top package.

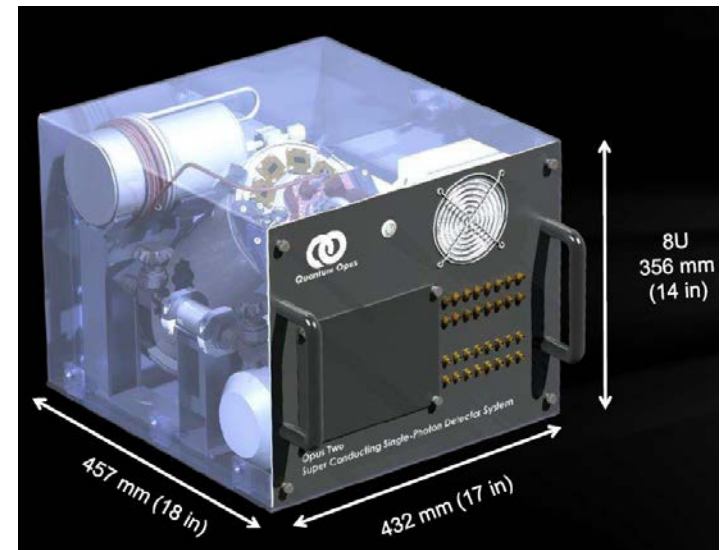
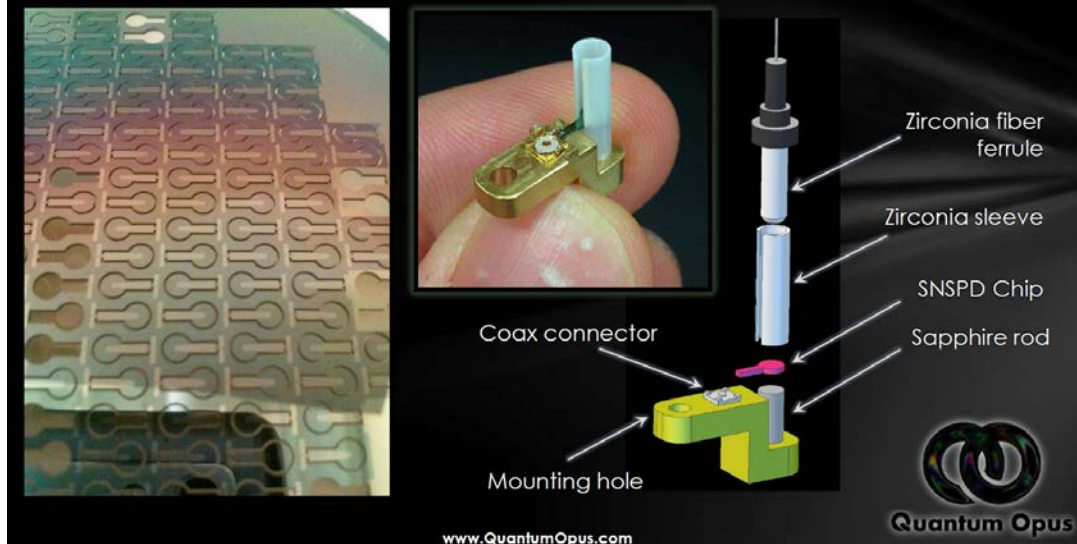



OPPORTUNITIES TO GET INVOLVED

Students: Quantum sounds cool, but...I'll NEVER find a job



- **Science in academia and industry**

- Physics – theory, experiment, instrumentation
- Chemistry – use quantum computers to simulate molecular ground states
- Biology - Imaging

- **Engineering**

- Electrical Engineering
- Optics
- Mech. E.
- Materials science
- Computer science
- Circuit design / VLSI

- **Business**

- Management of LARGE programs/projects
- Management of startups
- Management of research in large corporations

The New York Times

The Next Tech Talent Shortage: Quantum Computing Researchers

By Cade Metz

Oct. 21, 2018

Christopher Savoie, founder and chief executive of a start-up called Zapata, offered jobs this year to three scientists who specialize in an increasingly important technology called quantum computing. They accepted.



- **Quantum Computing**

- Using the full quantum state of a quantum system allows computation of some (one) important problems exponentially faster than with any classical computer
- Currently at TRL 3 – “research to prove feasibility” – If a modern computer has 1 billion transistors, current quantum computers have 10 - 20 quantum bits.
- Leading technology companies are at the forefront of development (IBM, Google, Intel)
- Plenty of evidence foreign governments are investing

- **Quantum Communication**

- Can implement a provably secure method for crypto-key material distribution – vice trusted courier or Public Key Infrastructure (PKI)
- Currently at TRL 9 – commercial systems are available for purchase
- Integration/compatibility with COMSEC / INFOSEC infrastructure is a question
- Extraordinary investment from foreign governments...and we don't know why.

- **Quantum Sensing**

- Can offer improved sensitivity for measuring certain quantities
- Currently at TRL 2 – Basic research
- Non-classical “quantum” states are highly sensitive to attenuation through the environment. Classical states are robust to loss and quantum techniques are still very important.

Optical Sensing and Communications



	Where are we now?	Where do we want to be?	How can quantum information help?
Optical Sensing	Direct and/or coherent detection – limited by noise in signal and/or detectors	Omni-presence – sensing all available signals over all frequencies at the sensitivity limit allowed by the laws of nature	Tools developed within the QIP community have shown to be required for reaching the fundamental limits of sensitivity.
Communications	Long-distance free-space comms dominated by RF, wired comms in fiber. PKI and other security infrastructure.	Unlimited bandwidth over unlimited distances through any medium with guaranteed security (for US).	Understanding the physical limitations of measurements of quantum states leads to development of: <ul style="list-style-type: none"> • Quantum-limited receivers for photon-starved applications • Understanding of an adversaries capability to intercept communications (QKD) • Physics-based approaches to information security
Computing			