

Association for Computing Machinery

June 10, 2026
Torrance, CA

Quantum 2.0: Computing, Communications, Sensors & Workforce Development - An Overview

Wednesday May 20, 2026

Knobbe Martens' Irvine offices

[2040 Main St # 14 Irvine, CA](#)

Make sure WiFi is connected to the Internet.

So YouTube videos run properly



Quantum Orange County

Coming soon

Donn Silberman
Founding Director
Quantum Optics Institute of
Southern California
<http://qoisc.org>



Topics

1. **How does Quantum 2.0 differ from 1.0?**
2. **Core Concepts: Qubits, Superposition & Entanglement**
3. **Quantum Qubits**
4. **Quantum Landscape – Key Players**
5. **Quantum Cybersecurity & Networking**
6. **Quantum Workforce Development**
7. **Summary & Future Trends – Quantum AI & ML**
8. **Questions & Answers**



Introduction

Who am I? And Why am I here talking to you?



Summer 1976

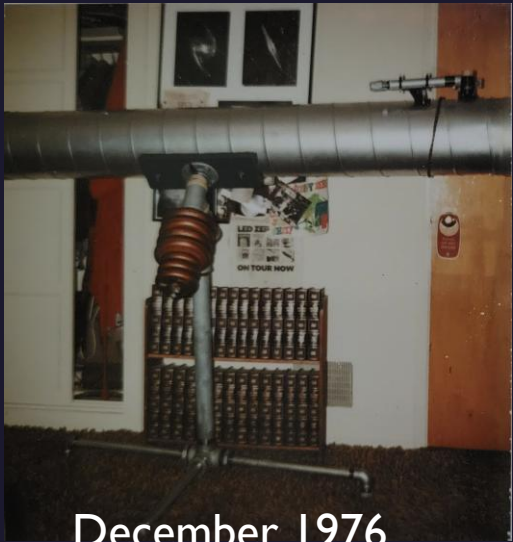

December 1976



Fall 1977

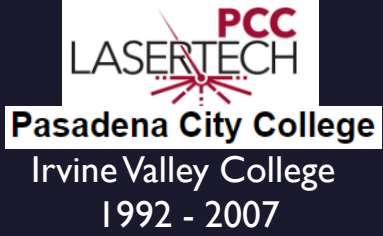

Society of Physics Students



1982

THE UNIVERSITY OF ARIZONA



1977



1979



1981

1983



1981

1983



2009

2026



2019



2017



2012



2014



2026



<quantum|gov>

QED·C
Member

NATIONAL QUANTUM INITIATIVE

THE FEDERAL SOURCE AND GATEWAY TO QUANTUM R&D ACROSS THE U.S. GOVERNMENT



President Trump Signed the National Quantum Initiative Act in 2018.

CONGRESS.GOV [Advanced Searches](#) | [Browse](#) [Search Tools](#) | [Support](#) | [Sign In](#)

[Legislation](#) | [Congressional Record](#) | [Committees](#) | [Members](#)

Legislation

[MORE OPTIONS](#)

[Home](#) > [Legislation](#) > [119th Congress](#) > S.3597 [Citation](#) [Subscribe](#) [Share/Save](#) [Site Feedback](#)

S.3597 - National Quantum Initiative Reauthorization Act of 2026

119th Congress (2025-2026) | [Get alerts](#)

BILL [Hide Overview](#)

Sponsor: [Sen. Young, Todd \(R-IN\)](#) (Introduced 01/08/2026)

Committees: Senate - Commerce, Science, and Transportation

Committee Meetings: [04/14/26 10:00AM](#) [03/25/26 10:00AM](#)

Latest Action: Senate - 04/14/2026 Committee on Commerce, Science, and Transportation. Ordered to be reported with an amendment in the nature of a substitute favorably. ([All Actions](#))

Tracker: Introduced Passed Senate Passed House To President Became Law

More on This Bill
[CBO Cost Estimates \(0\)](#)

Subject — Policy Area:
Science, Technology, Communications

Give Feedback on This Bill
[Contact Your Member](#)

Summary (0) | [Text \(1\)](#) | [Actions \(2\)](#) | [Titles \(2\)](#) | [Amendments \(0\)](#) | [Cosponsors \(19\)](#) | [Committees \(1\)](#) | [Related Bills \(0\)](#)

Summary: S.3597 — 119th Congress (2025-2026)

[All Information](#) (Except Text)

A summary is in progress.

NEWSROOM • DEMOCRATIC PRESS RELEASES

Led by Cantwell and Young, National Quantum Initiative Reauthorization Act Unanimously Passes Commerce Committee on World Quantum Day

■ *April 14, 2026*

Bill authorizes Federal investments vital to U.S. quantum development, a key technology for U.S. national security and global economic competitiveness

WASHINGTON, D.C. – Led by U.S. Senators Maria Cantwell (D-Wash.), Ranking Member of the Senate Committee on Commerce, Science and Transportation and Todd Young (R-Ind.), the National Quantum Initiative Reauthorization Act which will accelerate quantum technology development and real-world applications that are vital to U.S. national security and global economic competitiveness passed the Commerce Committee unanimously today. The legislation is cosponsored by Senators Dick Durbin (D-Ill.), Steve Daines (R-Mont.), Ben Ray Lujan (D-N.M.), Marsha Blackburn (R-Tenn.), Tammy Baldwin (D-Wisc.), Ted Budd (R-N.C.), Chuck Schumer (D-N.Y.), Mike Rounds (R-S.D.), John Fetterman (D-Penn.), Dave McCormick (R-Penn.), Andy Kim (D-N.J.), Tim Sheehy (R-Mont.), John Hickenlooper (D-Colo.), Bernie Moreno (R-Ohio), Tammy Duckworth (D-Ill.) and Roger Wicker (R-Miss.).

MAY 18-19, 2026 | UC SAN DIEGO

QSDC 26

QUANTUM SAN DIEGO CONVENING

[View Agenda](#)



The Quantum San Diego Convening (QSDC) will take place May 18-19, 2026 at UC San Diego, bringing together approximately 200 leaders from industry, academia, national laboratories, and government.

Sponsored by the California Governor's Office of Business and Economic Development (GO-Biz) as part of the Quantum California initiative, the convening is designed as a working forum to align priorities across the state's quantum ecosystem, with a focus on scaling quantum technologies. The convening takes place within the broader context of U.S. quantum initiatives, bringing together stakeholders whose work contributes to national priorities in advancing quantum technologies from research to deployment.

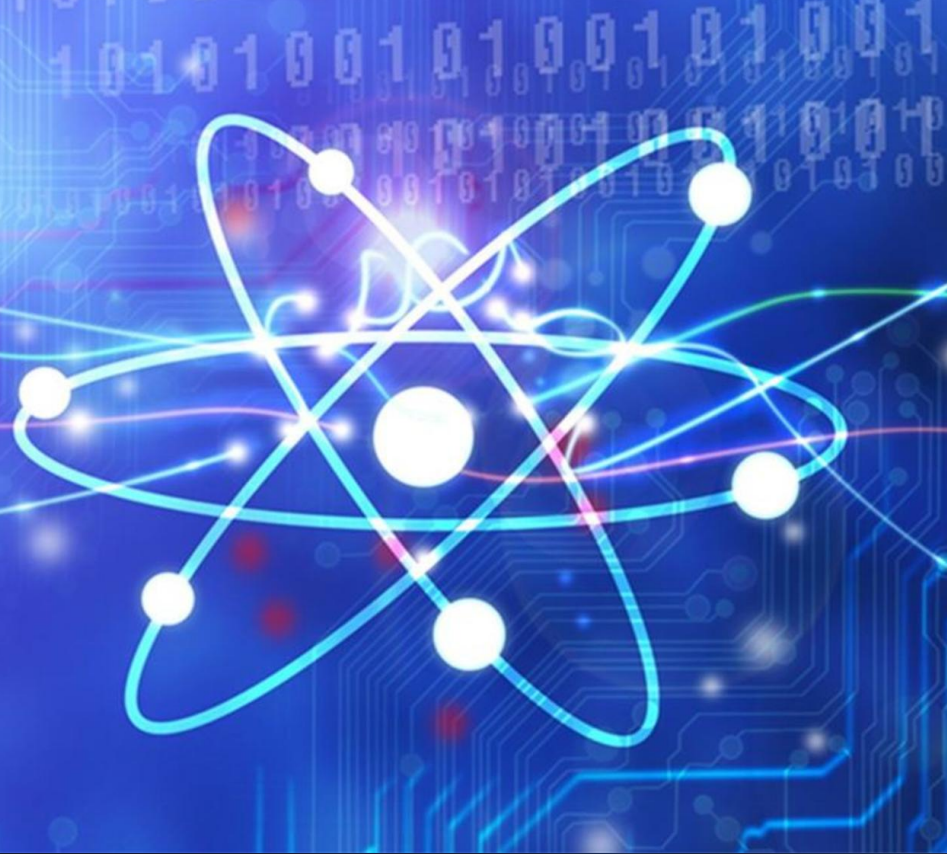

What is Quantum

Quantum 1.0 vs. 2.0

Things at the Atomic Scale are very different than at the human scale.

- The Quantum World underlies our current modern civilization. Quantum 1.0
- **And Quantum is about take humanity to the next level. Quantum 2.0**
- **You can help make it happen.**

QUANTUM 1.0

The story begins almost 100 years ago
The Solvay International Conference on Electrons & Photons October 1927
The "Quantum All Stars!!"

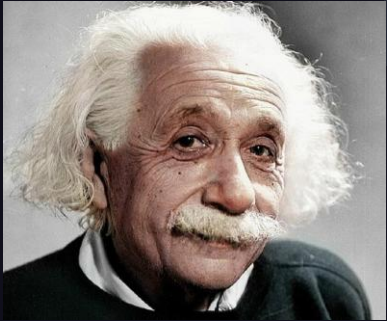

Albert Einstein



Max Planck



Werner Heisenberg



SOLVAY CONFERENCE 1927
A. PICARD E. HENRIOT F. EHRENFEST Ed. HERSEN Th. DE DONDER E. SCHRÖDINGER E. VERSCHAFFELT W. PAULI W. HEISENBERG R.H.FOWLER L. BRILLOUIN
P. DEBYE M. KNUDSEN W.L. BRAGG H.A. KRAMERS P.A.M. DIRAC A.H. COMPTON L. DE BROGLIE M. BORN N. BOHR
I. LANGMUIR M. PLANCK Marie CURIE H.A. LORENTZ A. EINSTEIN F. LANGÉVIN O.E. GUYE C.T.R. WILSON G.W. RICHARDSON
Admins: Dr W.H. BRAGG, H. DESLANDRES et E. VAN AUDEL



Niels Bohr



Erwin Schrödinger



Marie Curie

17 of the 29 attendees were or became Nobel Prize winners, including Marie Curie, who alone among them, had won two Nobel Prizes in physics and chemistry.

PRE-QUANTUM MYSTERIES

ATOMIC SPECTRA



THE STABLE ATOM



RADIOACTIVITY

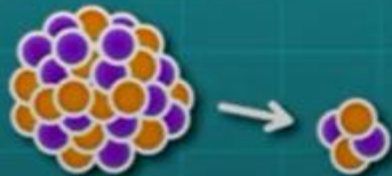

BLACKBODY RADIATION

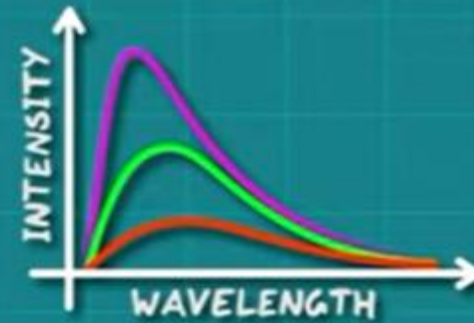

PHOTOELECTRIC EFFECT

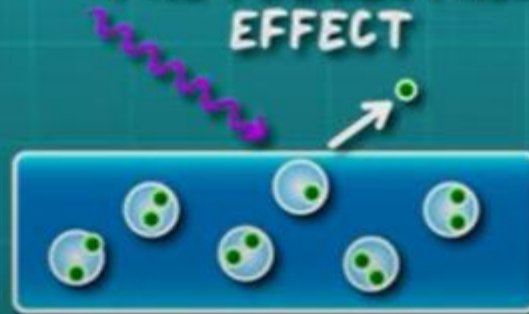

Isaac Newton & the Prism

Experiments first done in 1665 while he was a student
Studying at Cambridge University.

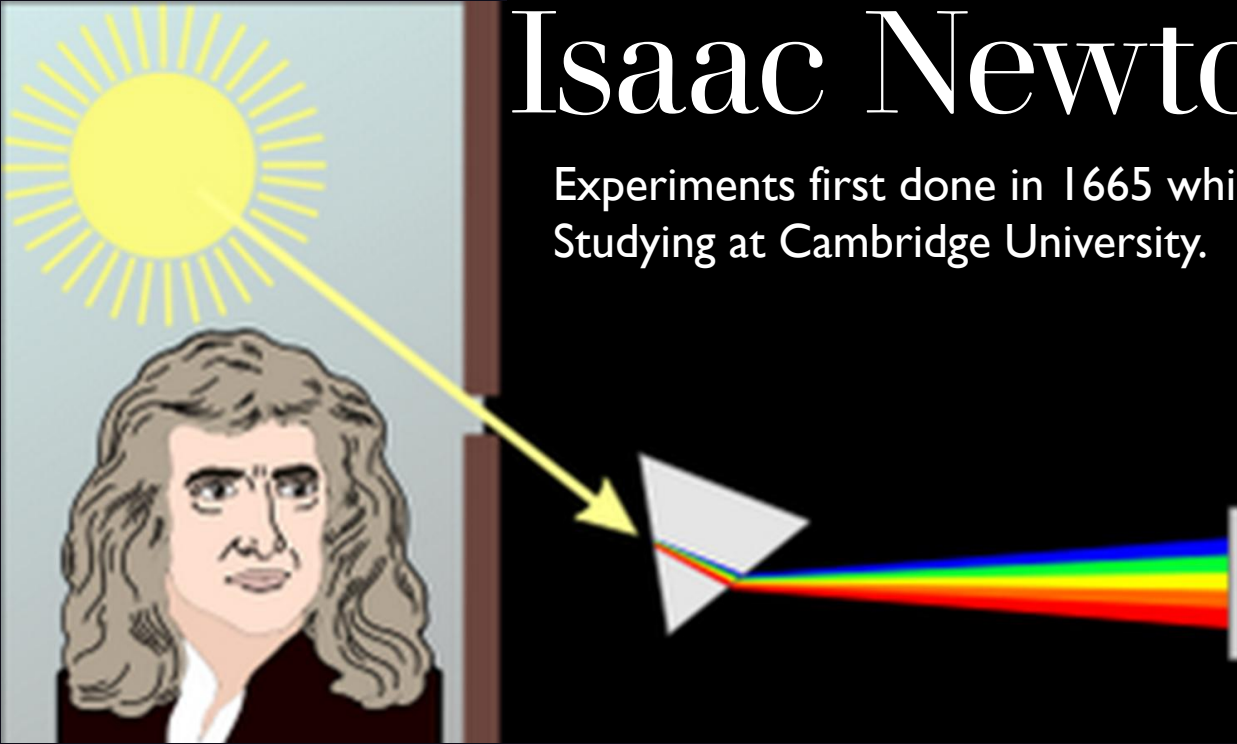

The Solar Spectrum with Fraunhofer Lines

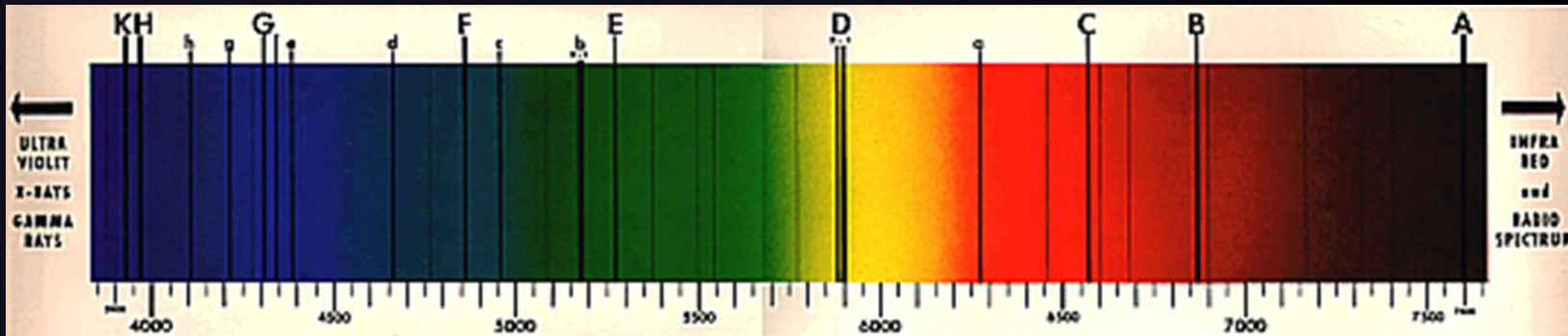

Discrete spectral lines correspond to the energy levels of various atoms that are burning in the Sun's atmosphere. Studied in detail by Fraunhofer beginning in 1814.

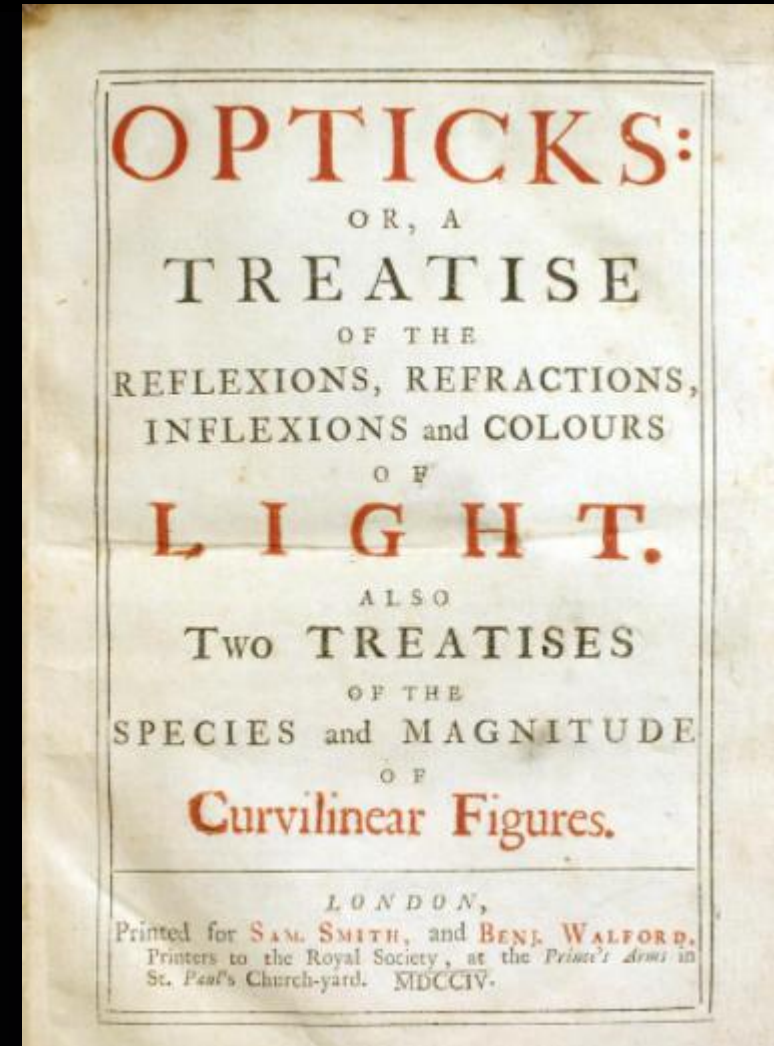

The first, 1704, edition of *Opticks: or, a treatise of the reflexions, refractions, inflexions and colours of light.*

[History of the transistor – Wikipedia](#) “After WWII, Shockley decided to attempt the building of a triode-like semiconductor device. He secured funding and lab space, and went to work on the problem with Bardeen and Brattain. John Bardeen eventually developed **a new branch of quantum mechanics known as surface physics** to account for the “odd” behavior they saw, and Bardeen and Walter Brattain eventually succeeded in building a working device.”



We have been living in the 1st Quantum Revolution for decades

The Transistor

The collage features several images: a vacuum tube labeled '1941', a small chip labeled '1967', a transistor labeled '1957', a hand holding a transistor labeled '1997', a transistor labeled '1948', and another transistor labeled '1955'. A satellite is also visible in the upper right corner of the collage.



QUANTUM 1.0

From Wikipedia: QUANTUM

In physics, a quantum is the minimum amount of any physical entity involved in an interaction. The fundamental notion that a physical property can be "quantized" is referred to as "the hypothesis of quantization".

[1] This means that the magnitude of the physical property can take on only **discrete values** consisting of integer multiples of one quantum.

**Can't have 1 1/2 photons
Or 3/4 of an electron**

Graphic representation of an **electron** (red O) moving from one energy level to another, emitting or absorbing a **photon** (Energy) of light.

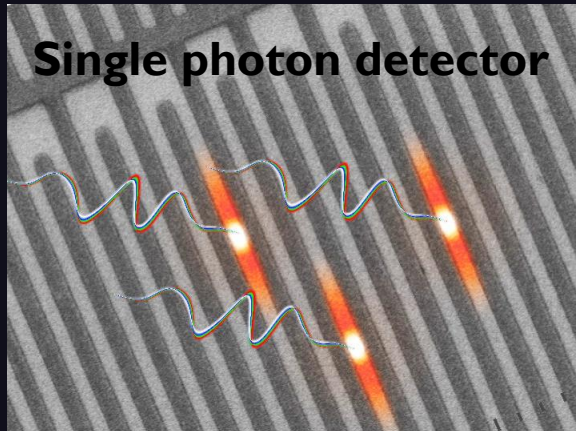

l-singlephoton.jpg (716x536) (b-cdn.net)

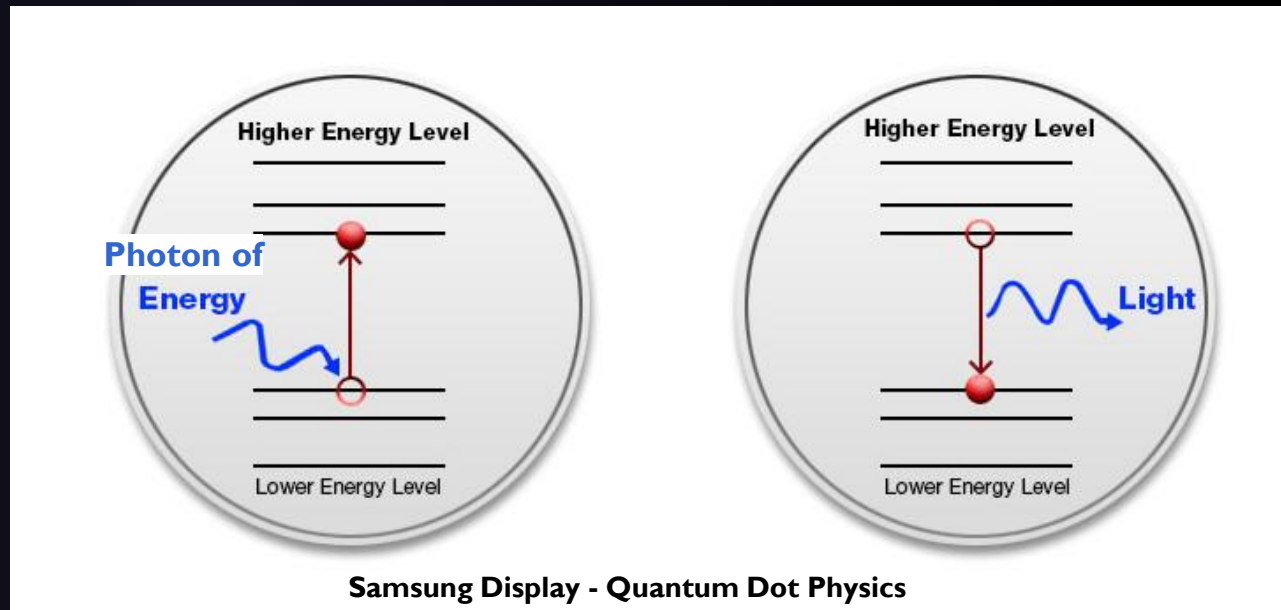

Samsung Display - Quantum Dot Physics

Single photon emitter

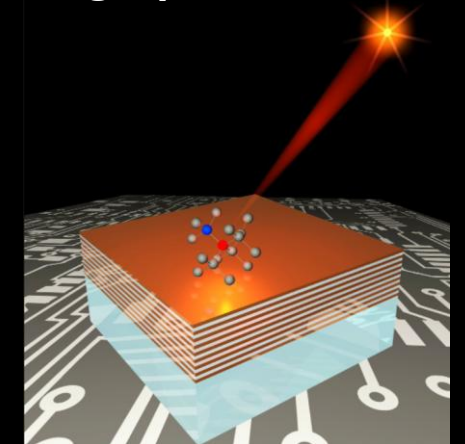

singlephoton.jpg (1000x1413) (b-cdn.net)

Max Planck's famous photon energy equation.

$$E = h\nu$$

frequency of radiation, sometimes written as f giving expression $E = hf$.
Quantum energy of a photon.
 $h = \text{Planck's constant} = 6.626 \times 10^{-34} \text{ Joule}\cdot\text{sec} = 4.136 \times 10^{-15} \text{ eV}\cdot\text{s}$

$$E = mc^2$$

Einstein's famous relativity equation
Energy = mass x speed of light²

QUANTUM I.0

Lasers are intrinsically quantum devices by their very nature.

A helium–neon laser demonstration. The glow running through the center of the tube is an electric discharge. This glowing plasma is the gain medium for the laser. The laser produces a tiny, intense spot on the screen to the right. The center of the spot appears white because the image is overexposed there.

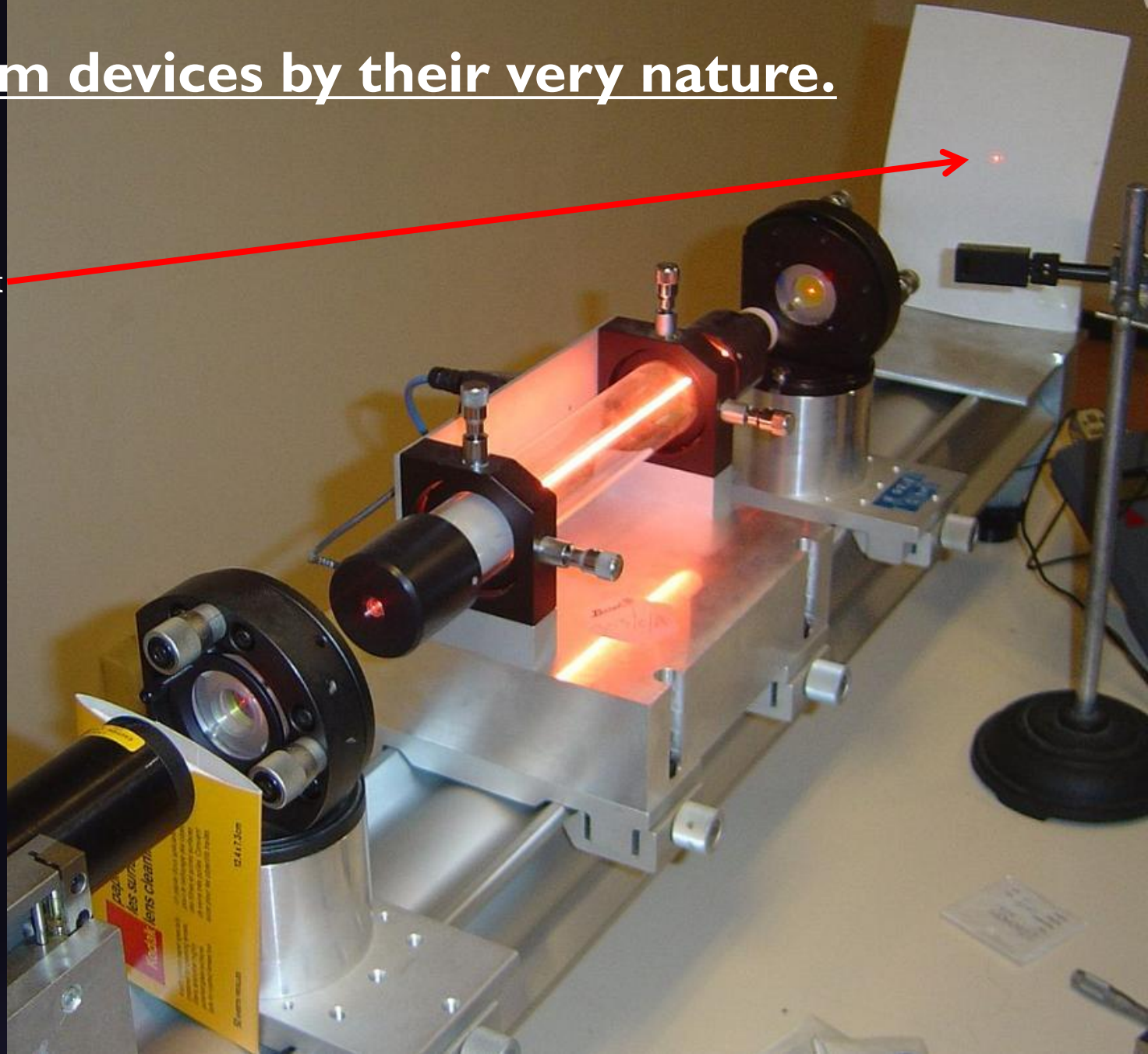

What are atoms & How do we know?

QUANTUM 1.0

The Bohr model of the atom

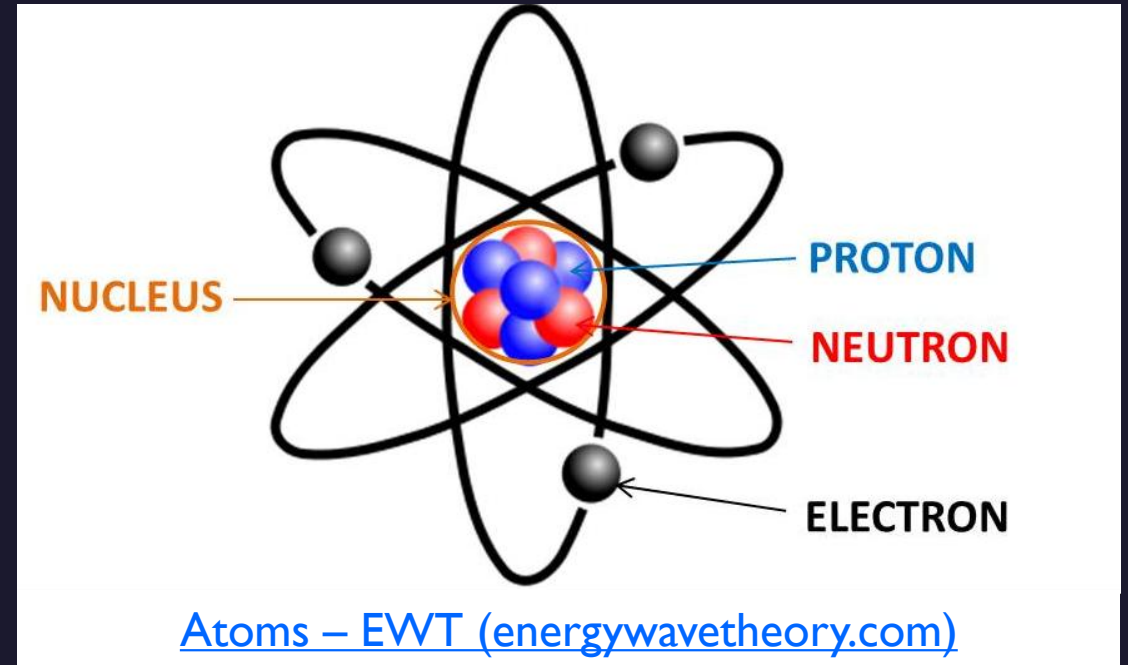
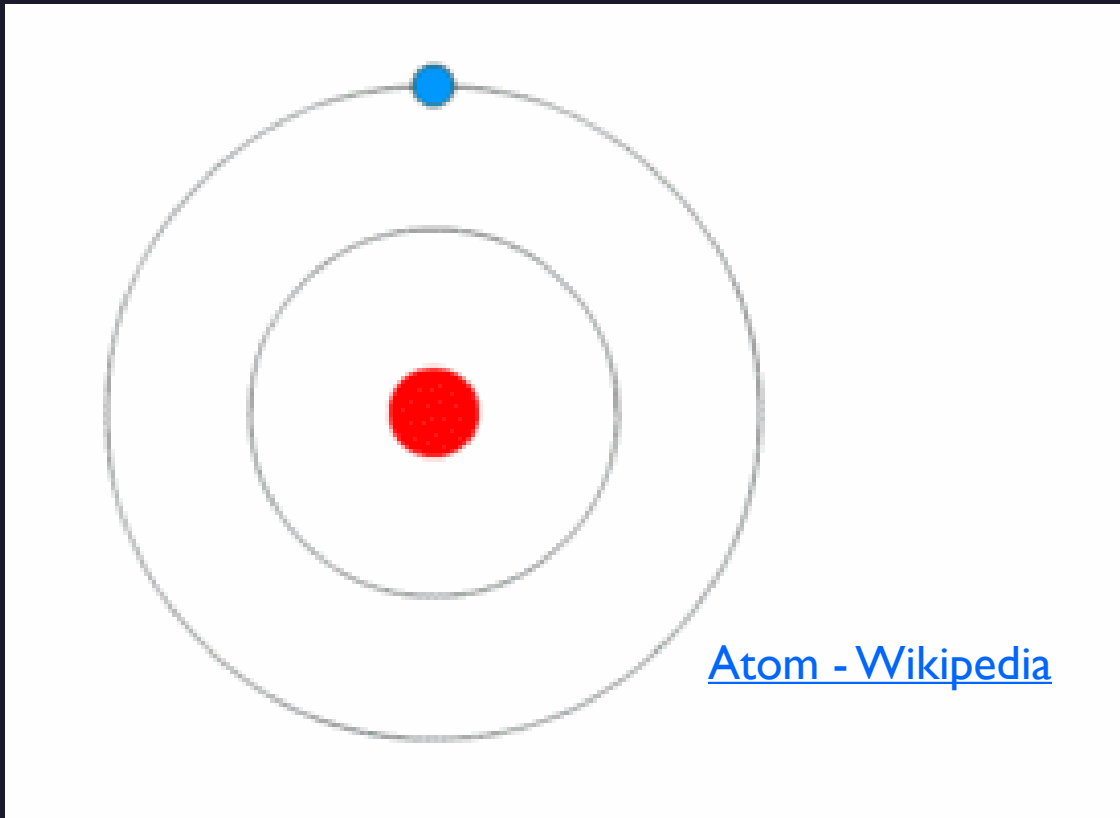

The Bohr model of the atom, with an electron making instantaneous "quantum leaps" from one orbit to another with gain or loss of energy. This model of electrons in orbits is obsolete.

Three Important Phenomena for The 2nd Quantum Science Revolution

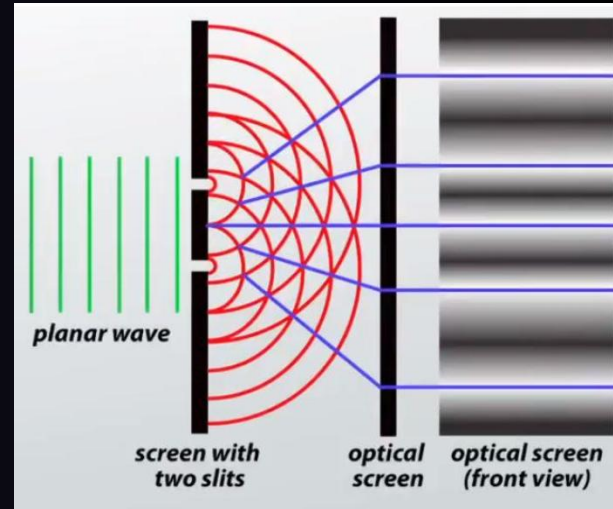
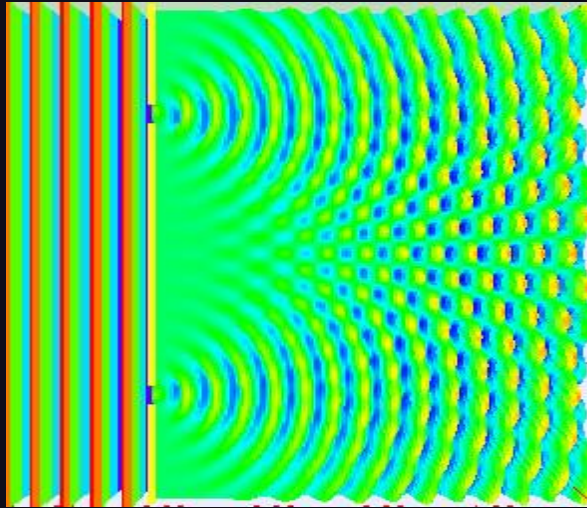

Wave / Particle Duality of Light (Interference)

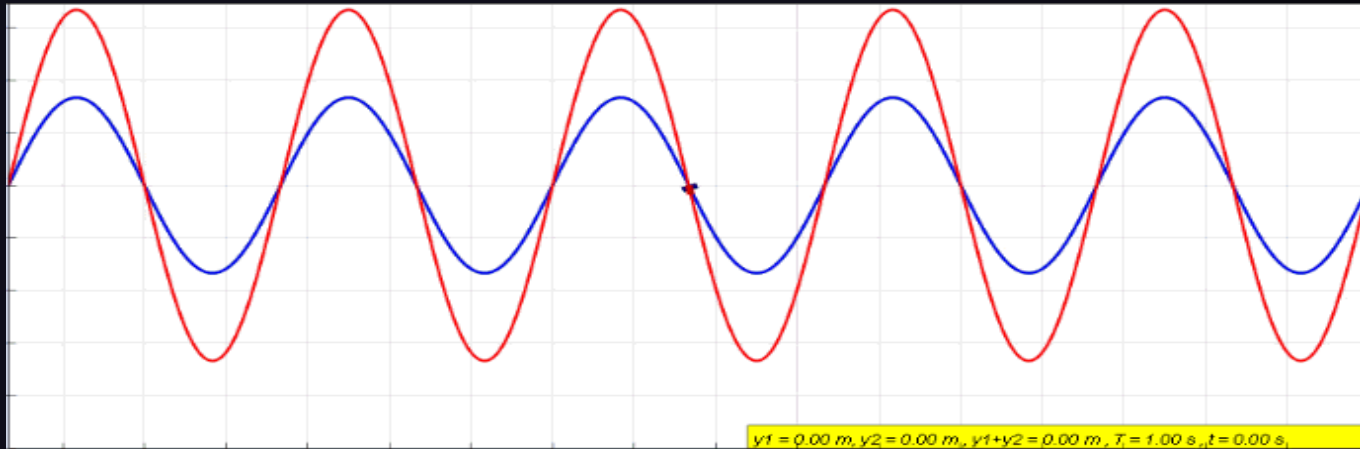

Superposition

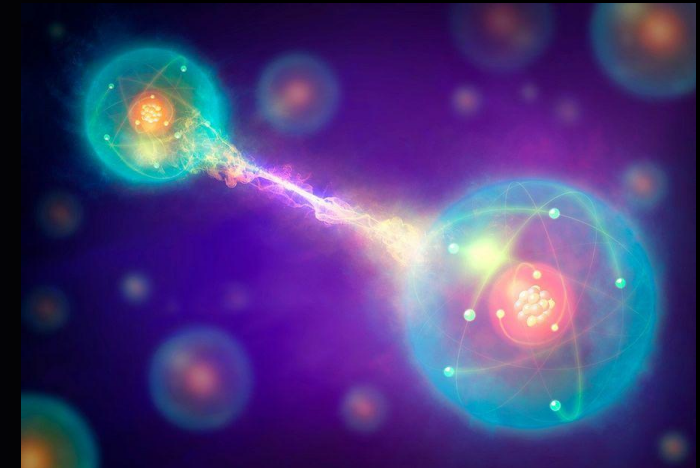

Entanglement
Einstein called this Spooky
action at a distance.

Explanations/Demonstrations of these properties:

Electrons and Photons behave like waves (double-slit experiment)
or particles (photoelectric effect)

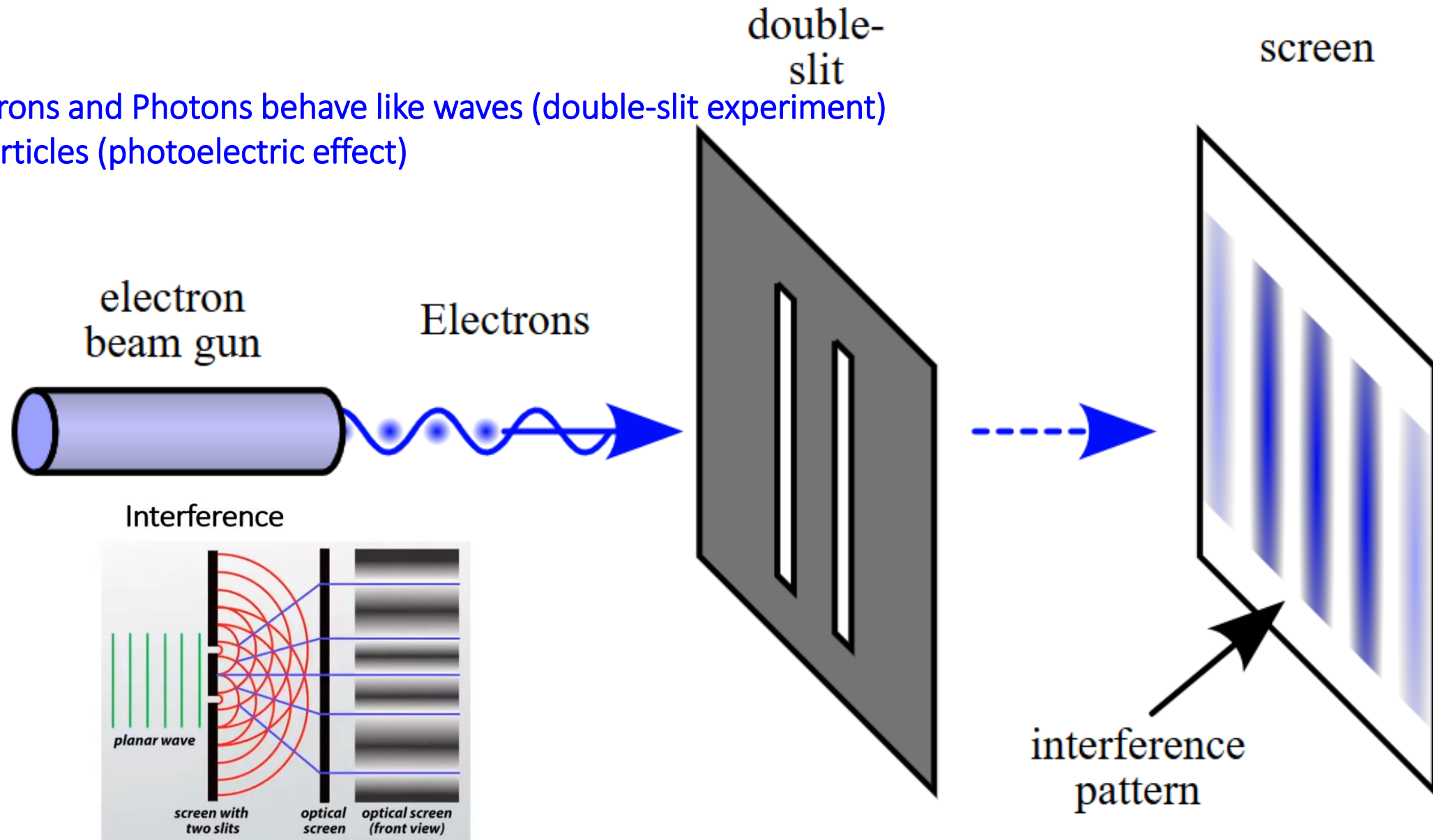

Particle impacts during a double-slit experiment. **The total interference pattern represents the original wave function**, while each particle impact represents an individual wave function collapse.

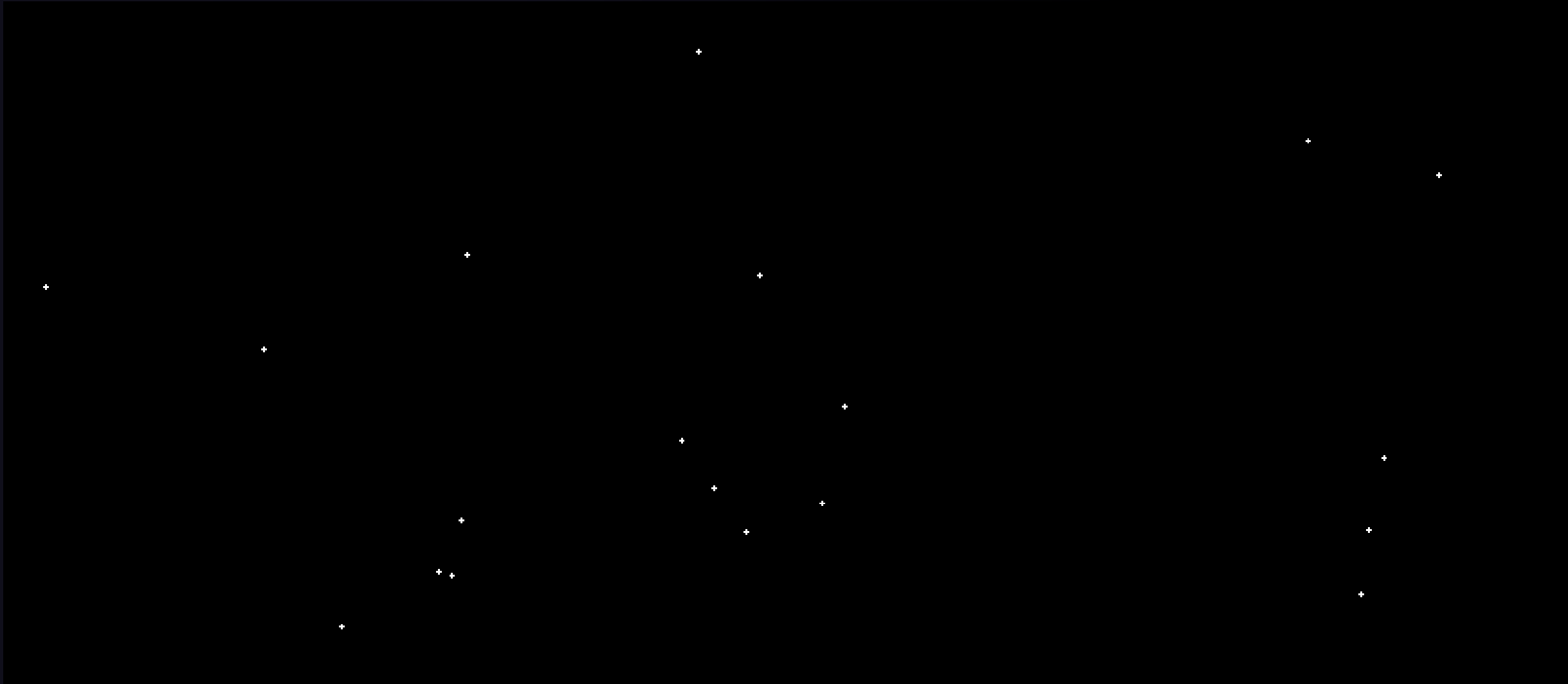

Thierry Dugnonle, CC0, via Wikimedia Commons.

Shooting particles through a double slit shows wave like behavior.

Superposition

(Classical examples like these are not good representation of quantum phenomena.)



1

0

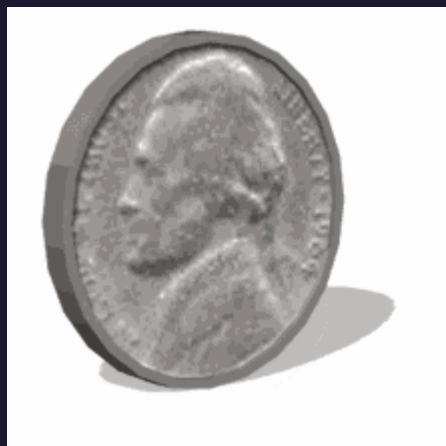

1 and 0



What Is the “Spooky Science” of Quantum Entanglement?

How can we use this for advanced computing, communications & sensing?

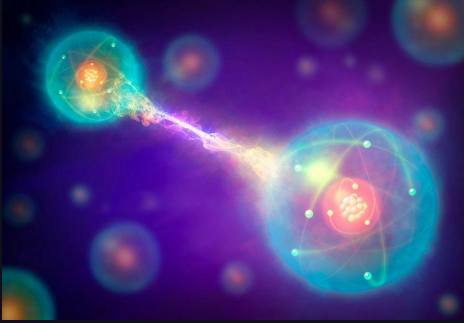

Non-Locality

- Entanglement means the “state” of one Qubit is “eternally and instantly” tied to the other, even if not in physical proximity
- Example: a pair of gloves is split into 2 boxes, then the boxes are separately shipped across the globe. Once you open one, you instantly know what the other is. *Not a good example because the quantum particles do have their states determined at the time of entanglement!!!*
- Things you can entangle:
 - Electrons (spin)
 - Photons (polarization)
 - Atoms (charge)
- If the entanglement is disrupted (noise, interception), it cannot be restored/copied/cloned – good for security

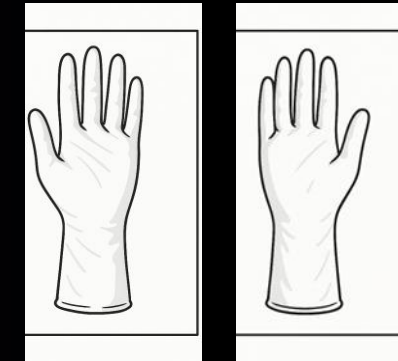
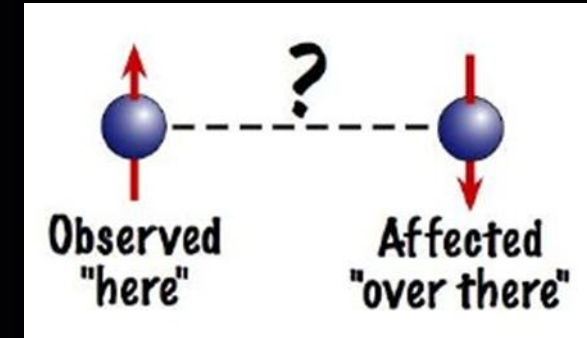

“Spooky action at a distance” – Albert Einstein

Note: Entanglement does not enable communication faster than the speed of light.

Random bits are not equal to useful data.

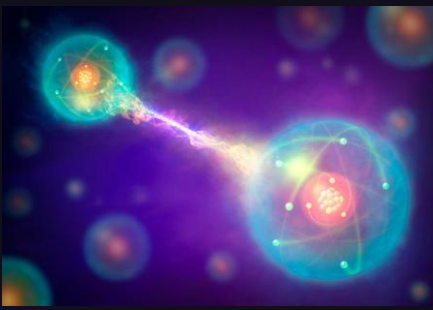

Quantum Entanglement of Photons via polarization

- This is what a lab setup looks like to entangle photons via polarization

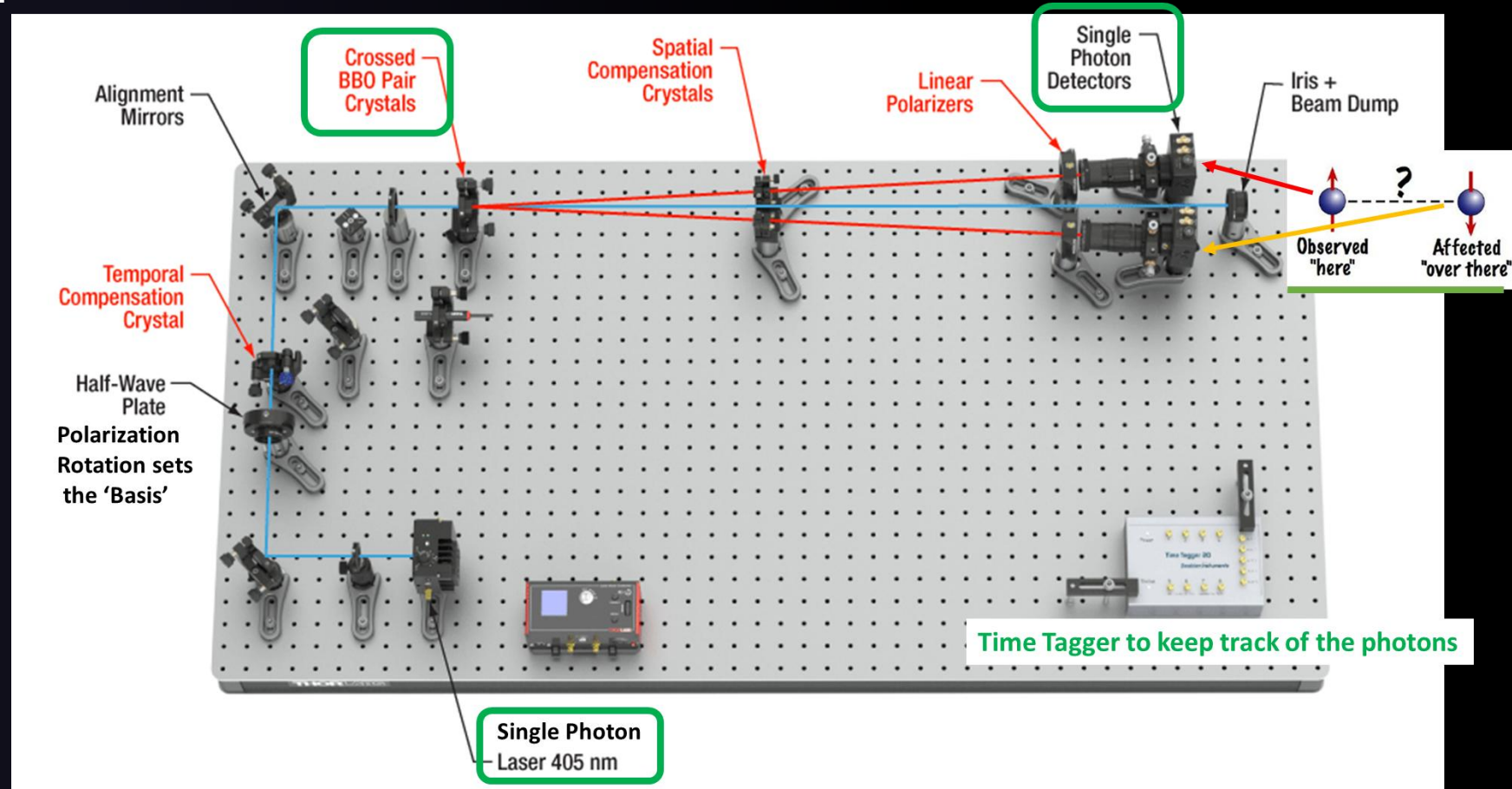
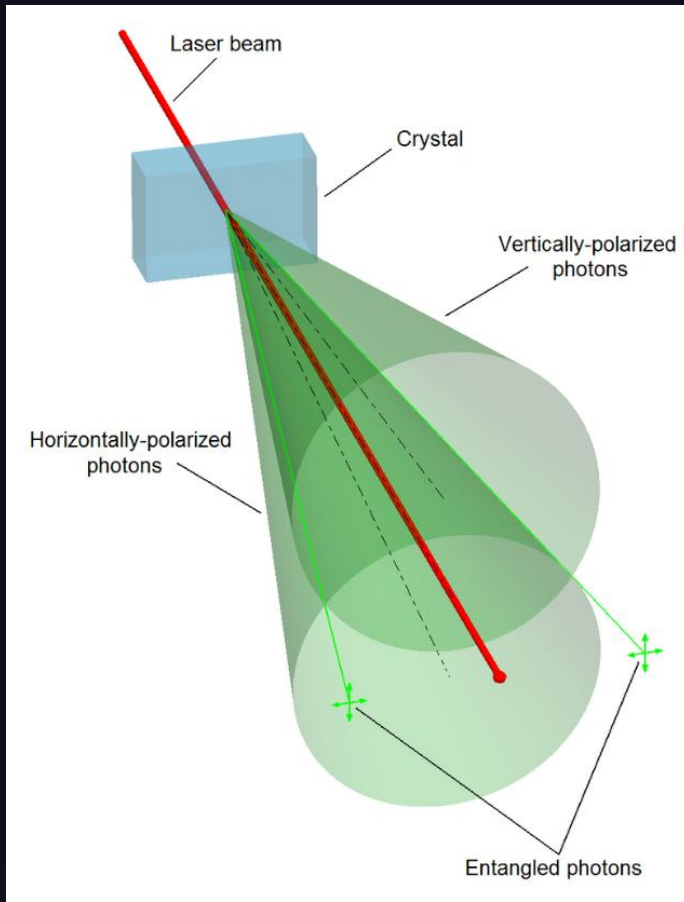

Thorlabs Polarization-Entanglement Extension Kit

Classical vs. Quantum computers



IBM desktop personal computer

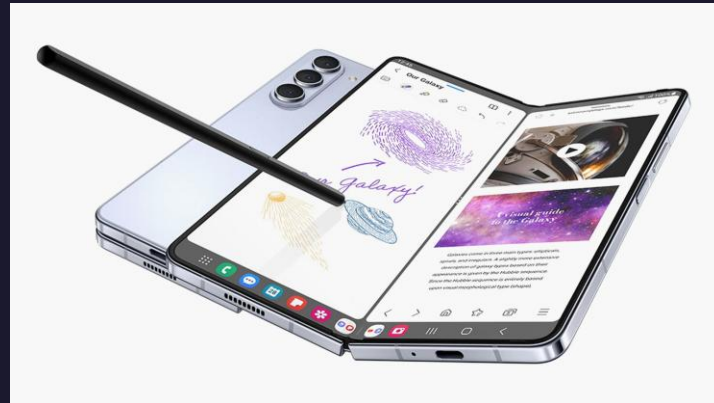

Cell phones are advance personal computer



High Performance Computer

<https://www.sandiegouniontribune.com/2017/01/25/ucsd-supercomputer-center-shaped-by-two-del-mar-residents-2/>



<https://ar.inspiredpencil.com/pictures-2023/quantum-computer>

Note that classical computers use the semiconductor quantum I.0 effect known as 'tunneling'.

<https://eureka.patsnap.com/report-quantum-tunneling-vs-classical-tunneling-energy-barriers>

Lots of misinformation about tunneling out there on the internet.

Elements of a traditional computer system

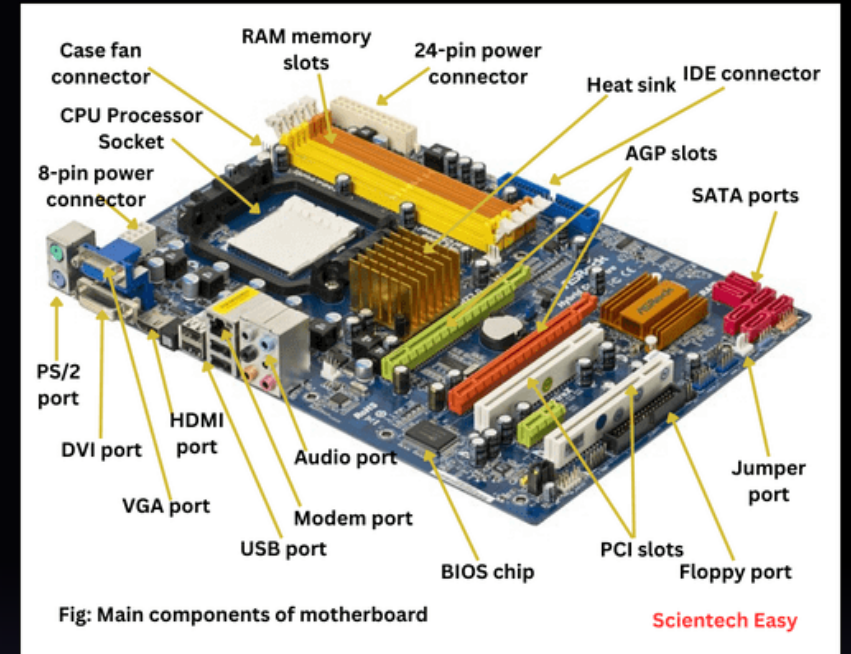
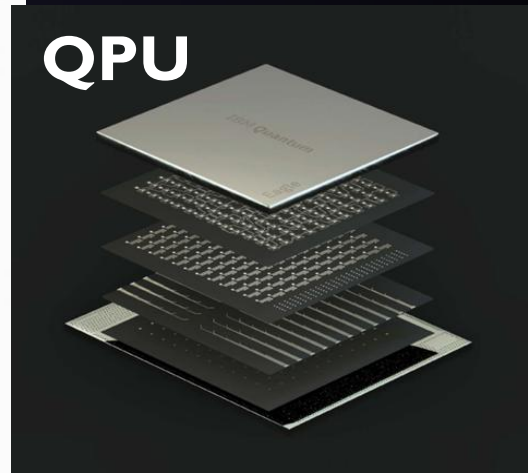
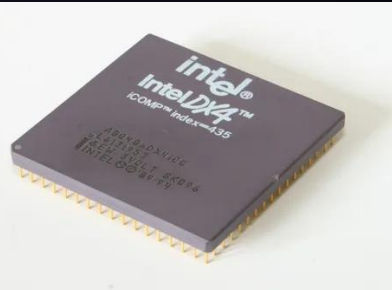
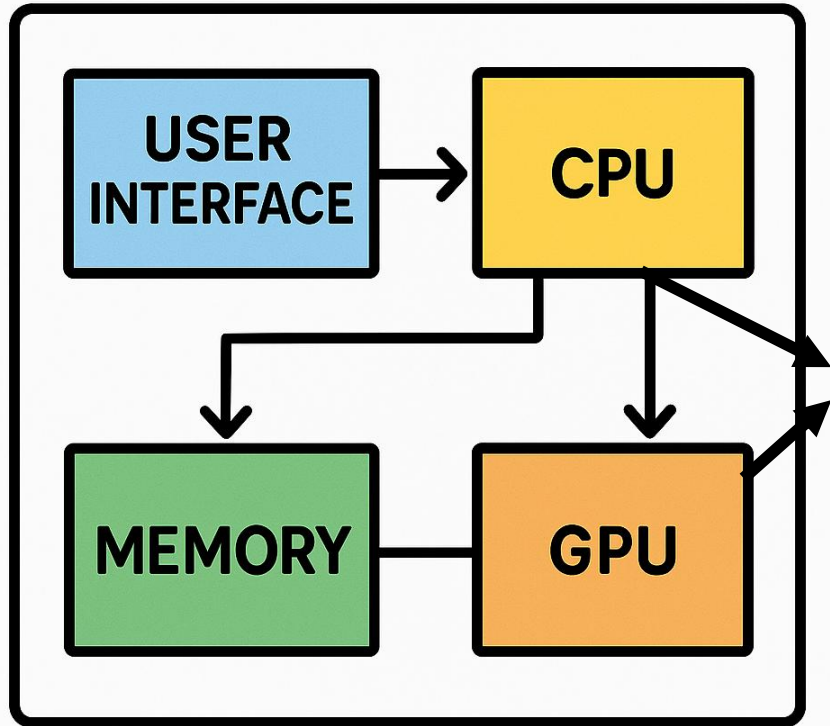

The “Quantum Processing Unit”(QPU) will likely operate in a hybrid configuration with a traditional computer, similar to the GPU

Bits vs. Qubits

Bit = On/off Switch
One "state" at a time

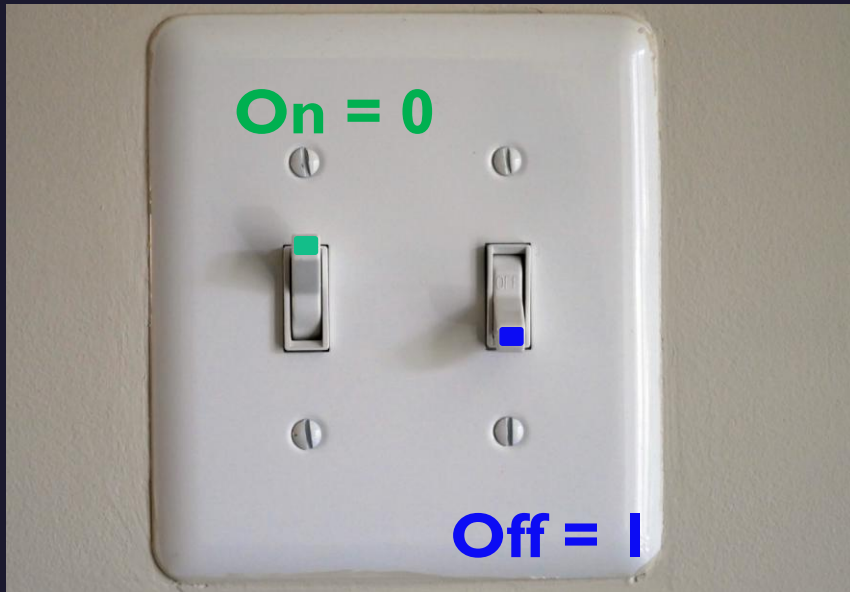

Think back to the transistors.

Imagine these switches are moving Very fast like in a computer, and there are Billions of very small ones in a semiconductor computer chip.

Qubit => Bloch Sphere
All "possible states" at the same time

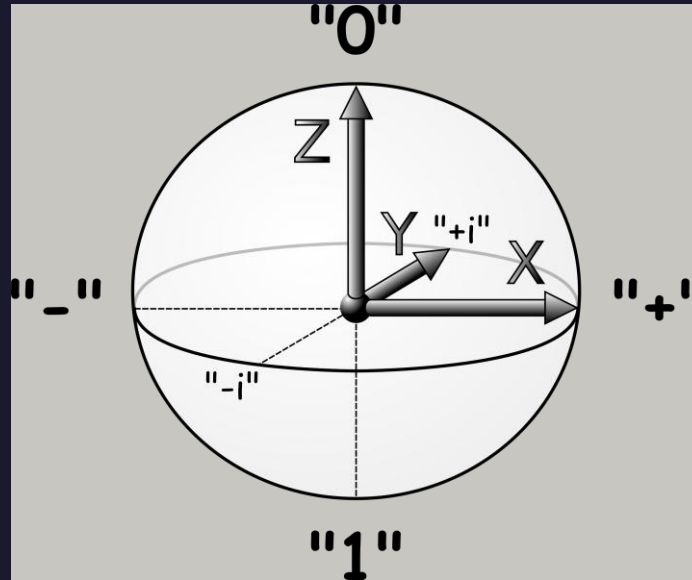

- Bloch sphere representation of a qubit
- The north pole represents "0"
 - The south pole represents "1"
 - The equator represents an equal probability of "0 and "1"
 - The longitude would represent the phase of the qubit.

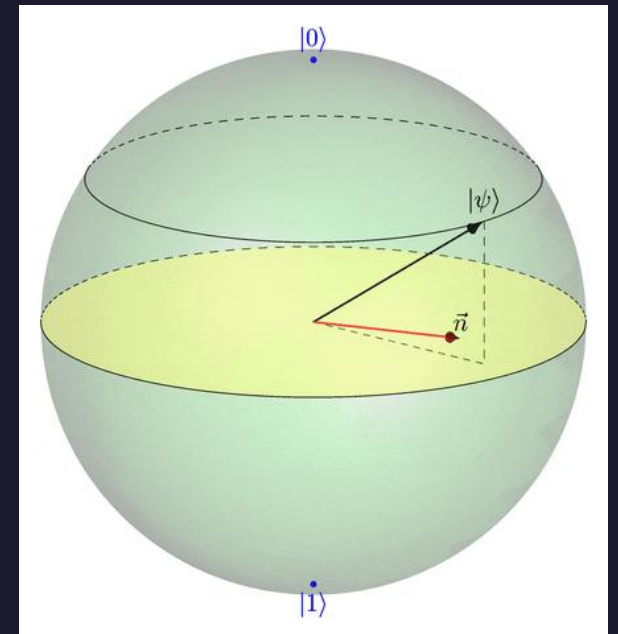

Bits vs. Qubits

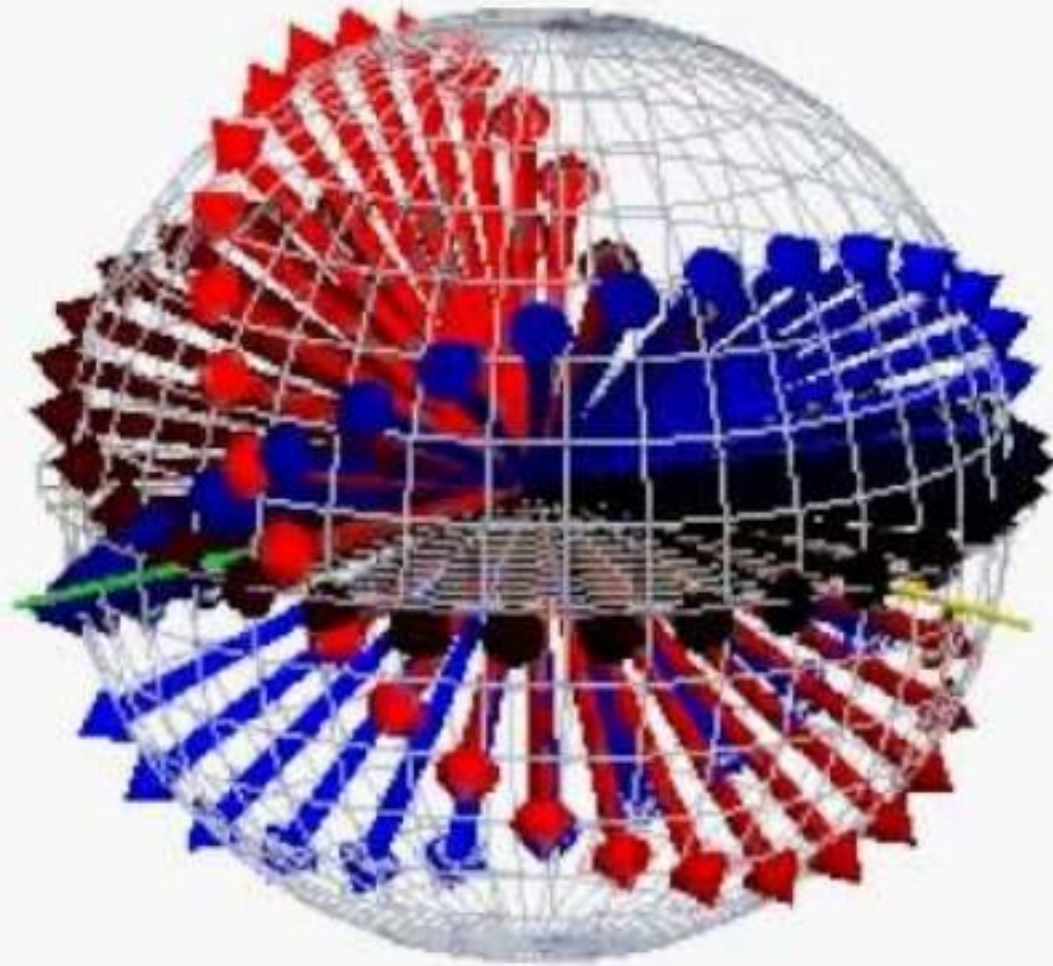

Classical vs. Quantum Computing

Using polarized photons of light as the Qubits

'Bra Ket' or 'Dirac' notation => Linear Algebra - vectors

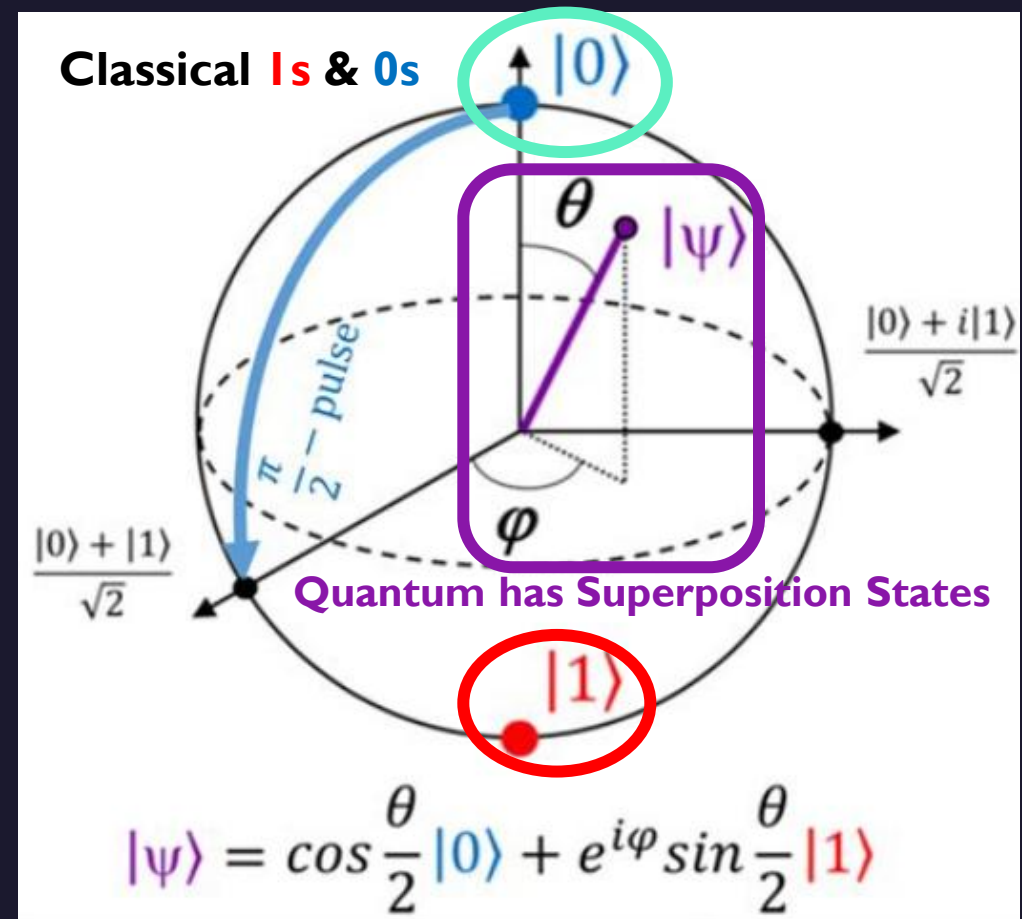
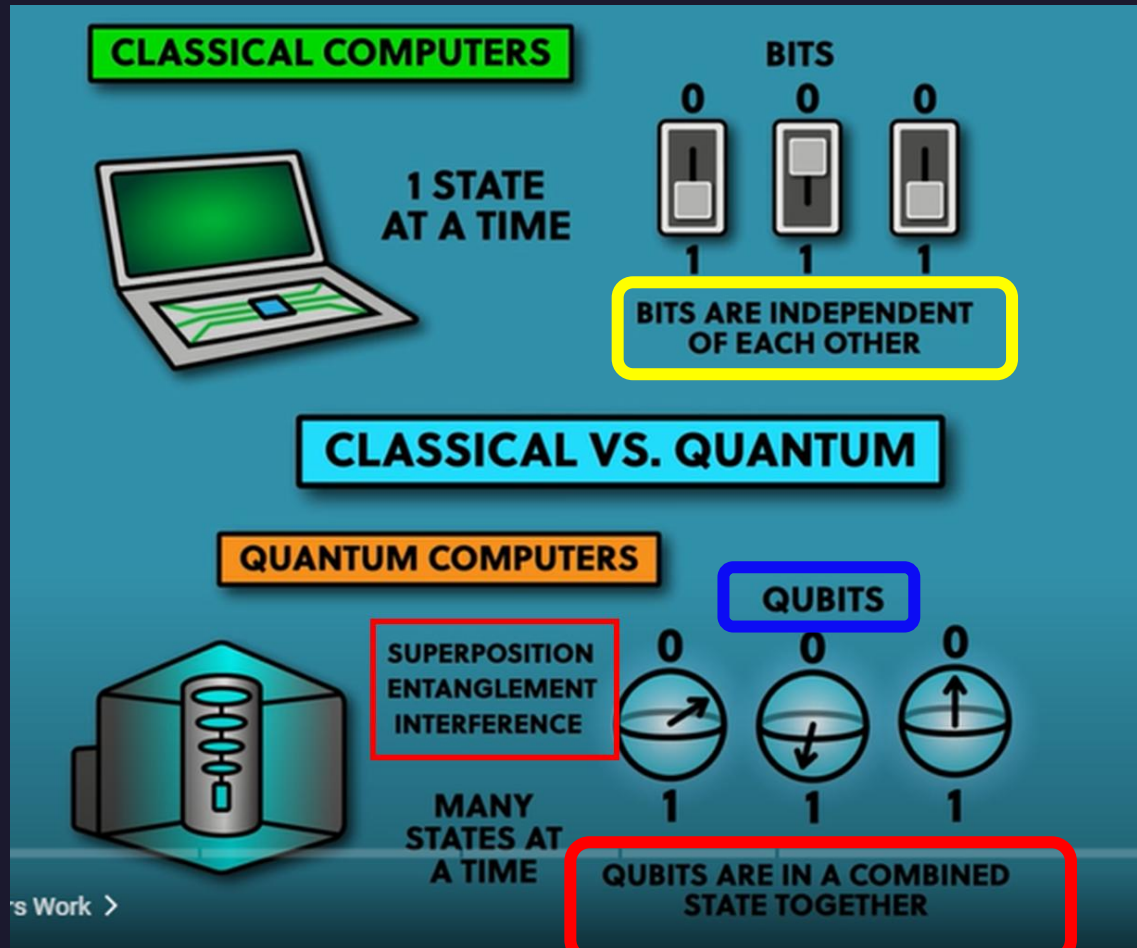

[The Bloch-sphere-provides-a-useful-means-of-visualizing-the-state-of-a-single-qubit-and.pptm \(850x770\) \(researchgate.net\)](#)

Bits vs Qubits

Using superposition and entanglement:

n qubits comparable to 2^n bits

qubits can hold an exponential number of states compared to the same number of classical bits

a **64**-qubit quantum computer computational power is 264 times faster than our 64-bit classical one, or 18 quintillion times faster

100 qubits can hold more states than all the hard drives in the world

300 qubits can hold more states than the number of atoms in the universe

<https://www.scienceabc.com/nature/universe/how-many-atoms-are-there-in-the-universe>

n	n	2^n
Number of Bits or Qubits	Classical Operations	Quantum Operations
1	1	2
10	10	1024
20	20	1,048,576
30	30	1,073,741,824
40	40	1,099,511,627,776
50	50	1,125,899,906,842,624

World Science Festival

Number of Bits or Qubits	Classical Operations	Quantum Operations
64	64	1.84e+19
100	100	1.26e+30
300	300	2.03e+90

<https://starlighttools.org/science/qubit-vs-classical-bit-calculator>

Quantum 2.0

Fundamental Quantum Computer Technologies

1. Super Conducting
2. Quantum Dots
3. Linear Optical (Photonic)
4. Trapped Ions
5. Color Centers
6. Neutral Atoms in Optical Lattices
7. Other Approaches
 - ✓ Electron-on-Helium Qubit
 - ✓ Magnetic Molecule - Spin
 - ✓ Cavity Quantum Electrodynamics
 - ✓ Nuclear Magnetic Resonance

PHYSICAL REALISATIONS

SUPERCONDUCTING QUANTUM COMPUTERS

QUANTUM DOT QUANTUM COMPUTERS

ALSO SILICON SPIN QUANTUM COMPUTERS

LINEAR OPTICAL QUANTUM COMPUTERS

TRAPPED ION QUANTUM COMPUTERS

COLOUR CENTRE QUANTUM COMPUTERS

NEUTRAL ATOMS IN OPTICAL LATTICES

OTHER APPROACHES

BY DOMINIC WALLIMAN © 2021 YOUTUBE DOMAIN OF SCIENCE

Different types of Qubits

Qubits are the physical devices with the elements inside.
(Elements = EM fields, Electrons, Ions, Atoms, Photons)

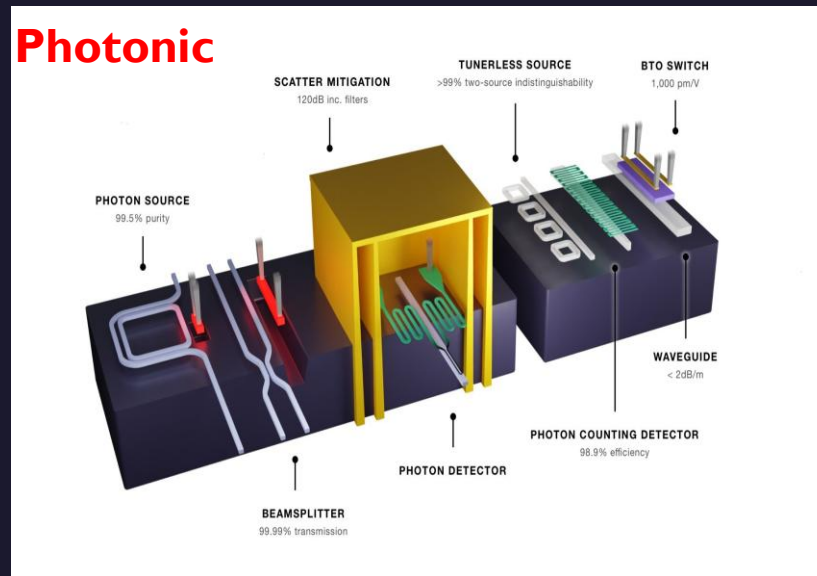
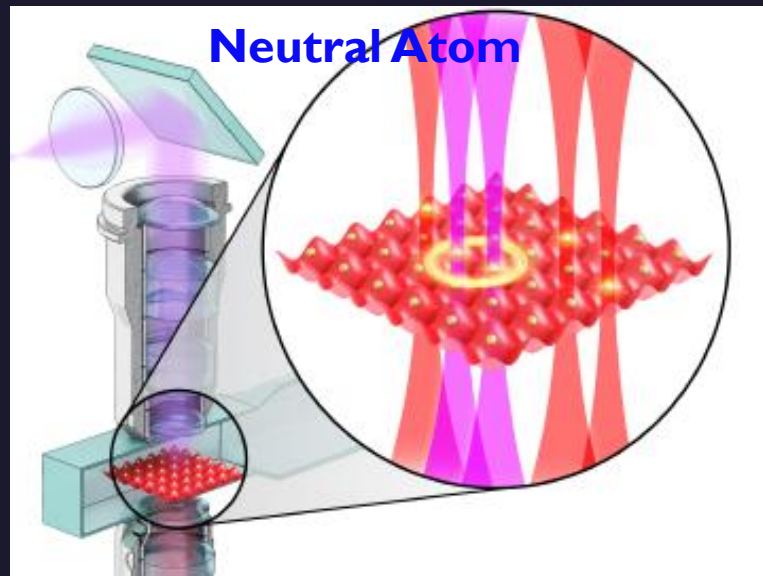
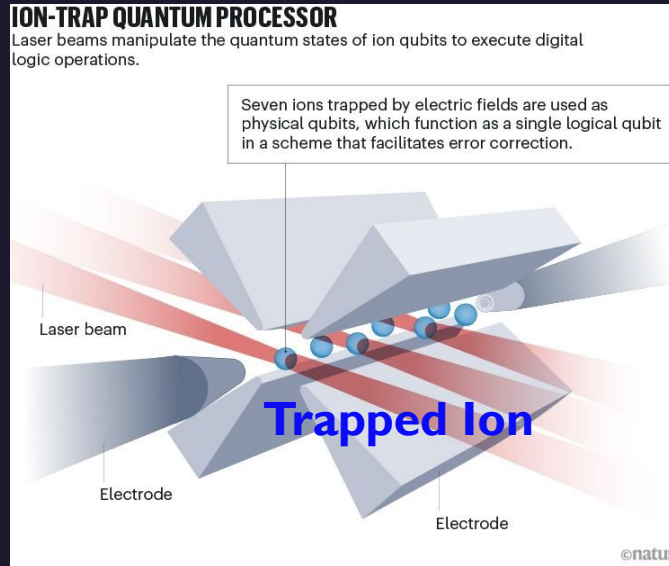
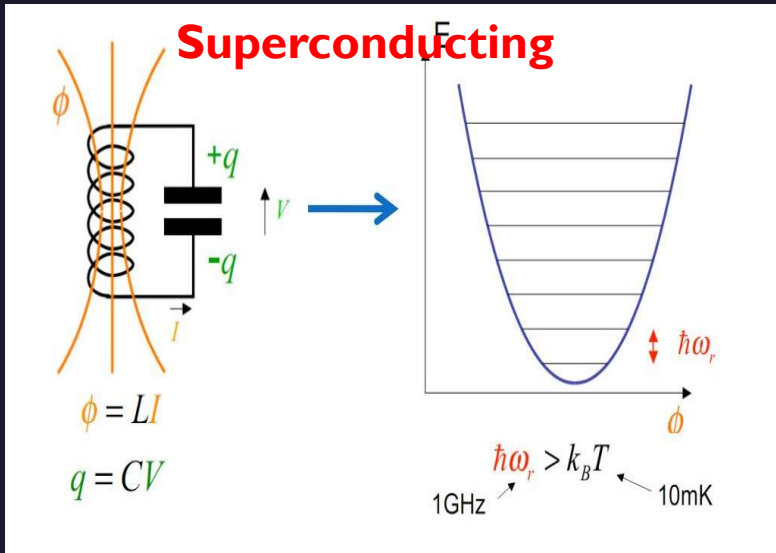

3 QUBITS TO KNOW

The building blocks of quantum technology are quantum bits - qubits. Qubits have special properties that form the foundations of quantum technology.

superconducting qubit

What it is

generated with superconducting circuits; manipulated via electromagnetic pulses

Advantages

based on technology already being used in semiconductors

Disadvantages

must be supercooled to temps of nearly 0 degrees Kelvin; easily lose superposition

In use by

Google, IBM, Rigetti, Intel

trapped ion qubit

What it is

ions enclosed by an electric field that can be manipulated using lasers

Advantages

longer life; easily interact with their neighbors; stable when in a superposition state

Disadvantages

like other systems, hard to scale-up and create larger systems

In use by

IonQ, Quantinuum, Alpine Quantum Technologies

photonic qubit

What it is

generated from entangled photons using various methods

Advantages

don't require supercooling; can use existing technology and infrastructure for networking

Disadvantages

easily deflected from their path resulting in lost quantum information

In use by

Xanadu, ORCA, PsiQuantum, Aliro

Curious about the future of quantum? Follow us!

[Twitter](#) [LinkedIn](#) @AliroQuantum

Companies working with different Qubit architectures



Qubit technologies

Superconducting

Google
IBM
amazon
rigetti
IQM

Neutral atom

ColdQuanta
IQuEra
Computing Inc.
PASQAL
atom
computing

Trapped ion

IONQ
Universal
Quantum
OXFORD
IONICS
AQT

Photonic

XANADU
PsiQuantum
ORCA
COMPUTING
QUIX
QUANTUM

Silicon spin / quantum dots

intel
Silicon
Quantum
Computing
QUANTUM
MOTION
diraq



Top 10 Companies in the Quantum Computing

Leading Providers in Quantum Technologies & Solutions

RANK	COMPANY	CATEGORY/SERVICE
1	IBM (US)	Quantum Computing Solutions
2	Google (US)	Quantum AI Research
3	Microsoft (US)	Quantum Computing & Azure Quantum
4	Amazon Web Services (US) <small>Sur-toradic Technology</small>	Quantum Cloud Services
5	intel (US)	Quantum Research & Hardware
6	D-Wave Quantum Inc. (CA) <small>Q - The Quantum Computed tion</small>	Quantum Annealing Solutions
7	Rigetti Computing (US) <small>Q - The Deep Unum Intel Cat</small>	Quantum Computing Platforms
8	IonQ (US)	Quantum Computing Hardware
9	Quantinuum (UK) <small>Q - The Quantum Computing</small>	Quantum Software & Hardware
10	FUJITSU (JP)	Quantum Computing Solutions

Verified Electronics + Follow ✕
 1,563 followers
 1w •

April 26, 2026

Top 10 companies in quantum computing.

Notice something: the top 5 are all hyperscalers, **IBM, Google, Microsoft, Amazon Web Services (AWS), Intel.**

That's not a coincidence.

Here's why quantum matters for data centers and AI:

- ◆ AI has a compute problem Classical GPUs keep scaling, but model sizes are outpacing hardware. Some optimization and training problems hit walls that silicon alone can't break. ...more

596 17 comments • 72 reposts

Like Comment Repost Send

Add a comment...

Most relevant ▾

Lucas Wager • 2nd SCC Partnership Leader 6d ...

Andrew Steve Andrew

Like • 1 | Reply • 2 replies

[See previous replies](#)

Lucas Wager • 2nd SCC Partnership Leader 6d ...

Andrew very interesting perspective, we

A new Microsoft chip could lead to more stable quantum computers

The company says it is on track to build a new kind of machine based on topological qubits.

By Rachel Courtland

February 19, 2025

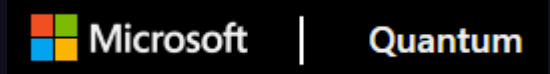

<https://quantum.microsoft.com/>

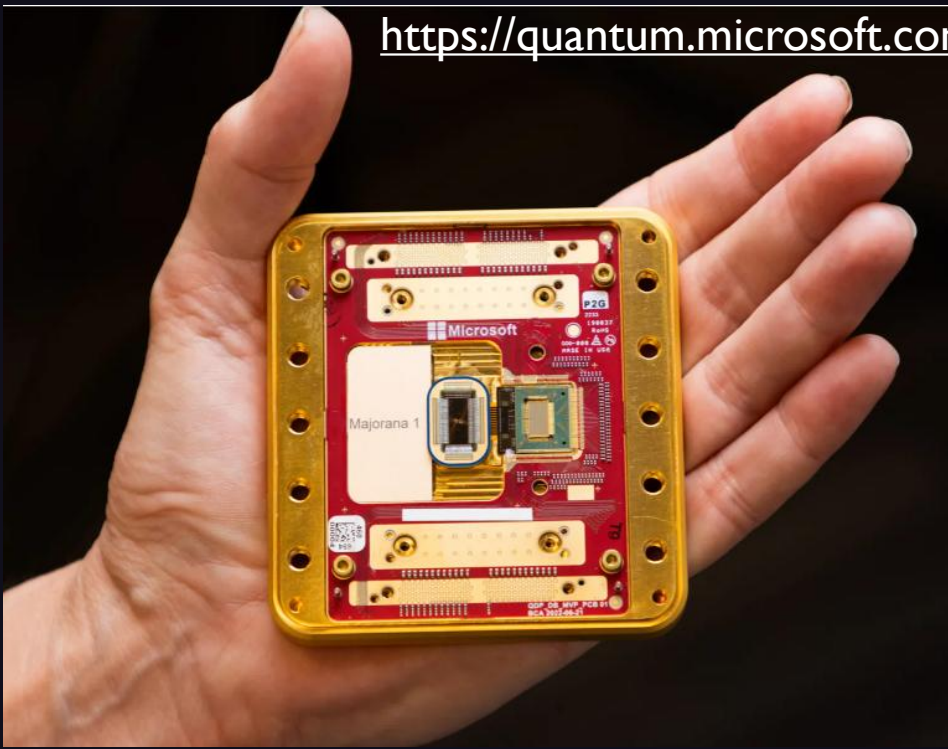

Microsoft has put eight of its new topological qubits on a chip, which it calls the Majorana 1.

Meet Willow, our state-of-the-art quantum chip



Hartmut Neven
Founder and Lead, Google Quantum AI

Dec 09, 2024
6 min read

Our new chip demonstrates error correction and performance that paves the way to a useful, large-scale quantum computer



Google Quantum AI

Explore Quantum AI

Superconducting Qubits

<https://quantumai.google/>

PsiQuantum Scaling up its Queensland Operations

Opens Asia-Pacific HQ in Brisbane's City Centre & Reveals New Renderings of Quantum

Computing Site at Brisbane Airport.



PsiQuantum's quantum computing site adjacent to Brisbane Airport.

<https://www.psiquantum.com/featured-news/brisbane-renders-office>

PsiQuantum To Build First US-Based Utility-Scale Quantum Computer in Chicago, Illinois

Will Anchor Governor J.B. Pritzker's Illinois Quantum and Microelectronics Park to be developed at the former US Steel South Works Site in the City of Chicago.

 PsiQuantum

[About](#) [Blueprint](#) [Research](#) [Careers](#) [News](#)



Rendering of the Illinois Quantum and Microelectronics Park. | Credit: Lamar Johnson Collaborative

<https://www.psiquantum.com/news-import/illinois-iqmp>



Quantum Photonic (Silicon) Integrated Circuit (QPIC) test & measurement

Quantum Computer Database Search

QUANTUM BITS

with Quantessa & Atomique

Posted on [April 5, 2026](#)

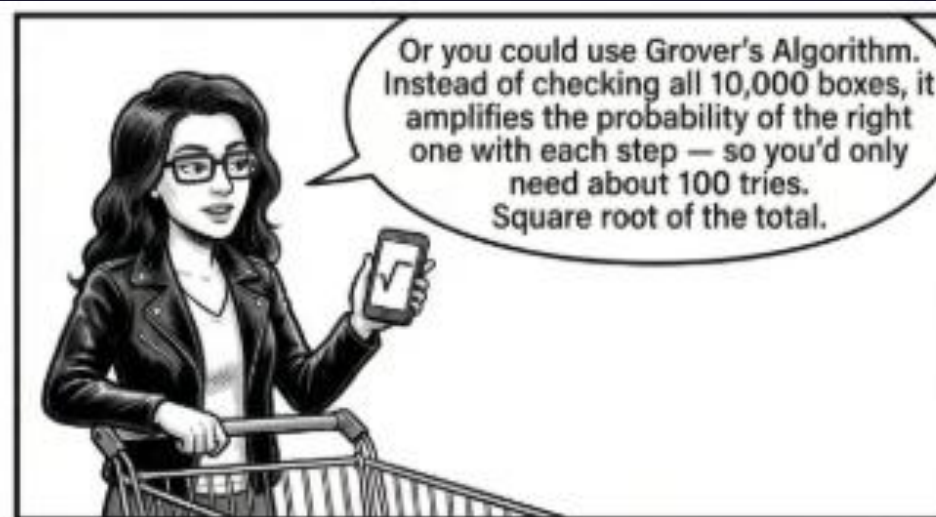

Quantum Computers & Cybersecurity

Quantum 2.0

Including cryptocurrencies and blockchain technologies

Risks & Opportunities

The global race to develop practical quantum computers that can 'hack' all current encryption technologies
Against the implementation of quantum resistant encryption technologies.

Intellectual property (IP) -

- in the public domain via patents and published papers
- Trade Secrets – held 'close to the vest'

A Primary Driver for Quantum Computing and Quantum Cybersecurity

This graphic is from 2021 – lots of progress has been made since then!!

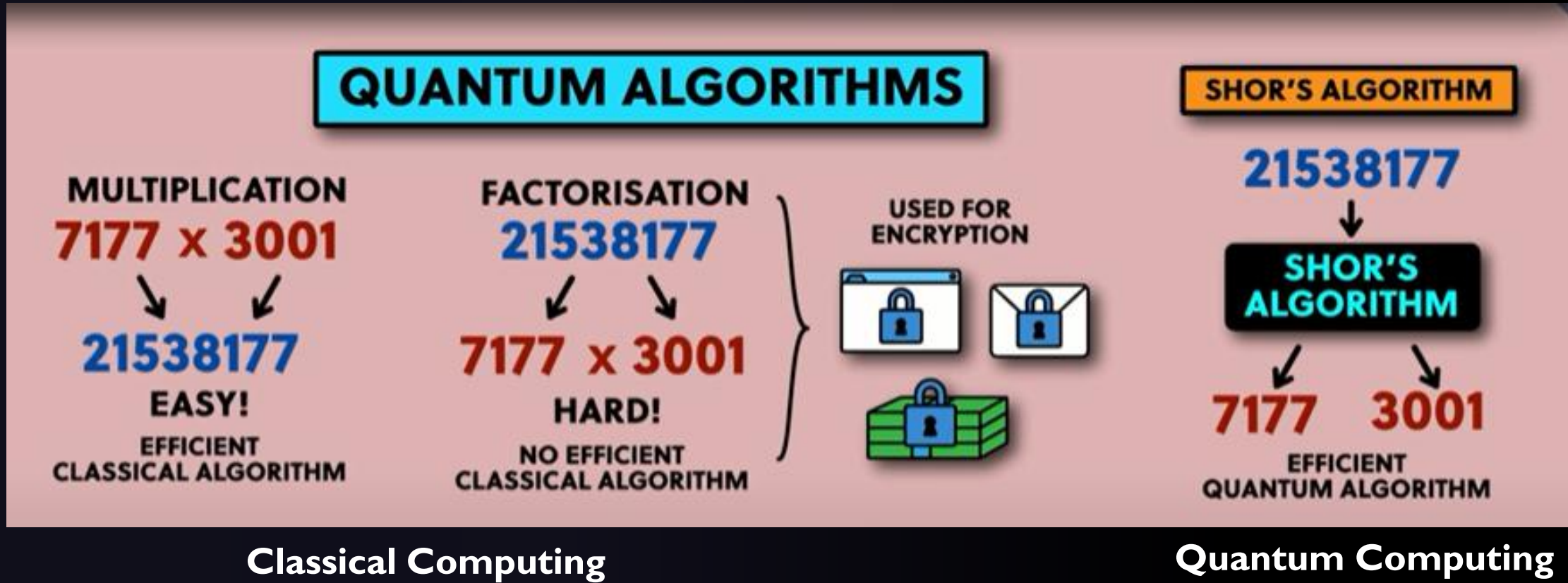

The Map of Quantum Computing | Quantum Computers Explained
DoS - Domain of Science – YouTube

Today, progress in both Quantum Computing and Quantum Cybersecurity has been faster than anyone predicted.

April 3, 2026

New Advances Bring the Era of Quantum Computers Closer Than Ever

Two research groups say they have significantly reduced the amount of qubits and time required to crack common online security technologies.

In Mikhail Lukin's lab at Harvard, physicists manipulate qubits made of atoms with finely controlled laser beams.

Manuel Endres & colleagues at Caltech recently published: "Shor's algorithm is possible with as few as 10,000 reconfigurable atomic qubits." <https://arxiv.org/abs/2603.28627>

There are a lot of 'assumptions' in many of these papers and experiments, but one thing is certain, people are making more progress than anyone predicted.

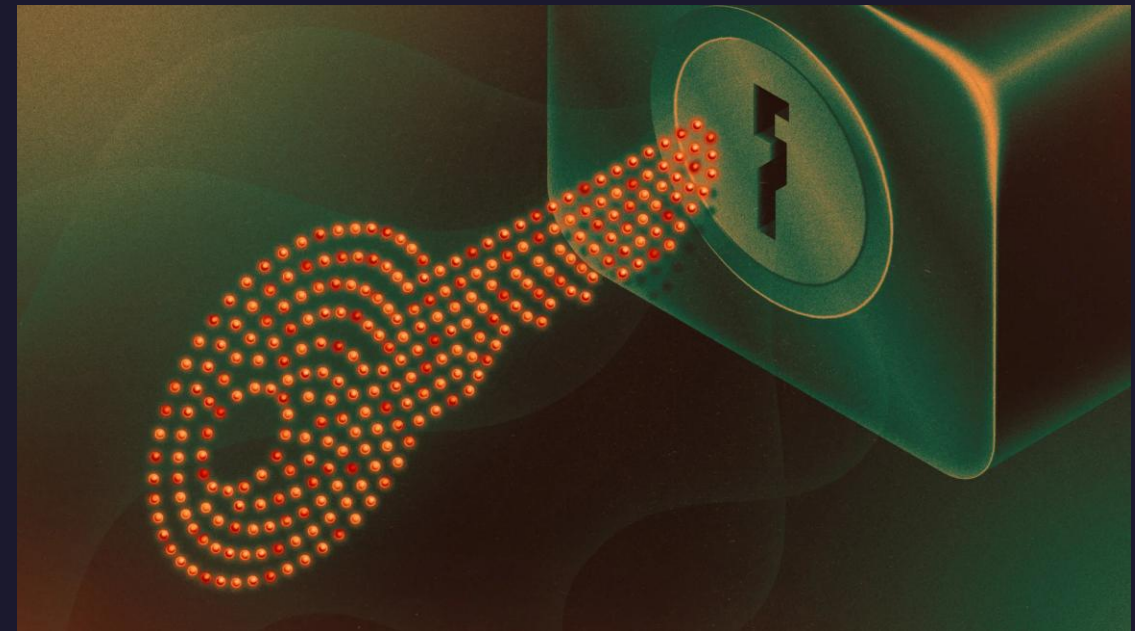

QKD: PART OF A DEFENSE-IN-DEPTH SECURITY STRATEGY

THE QUANTUM ECONOMIC DEVELOPMENT CONSORTIUM

A collective voice for the global quantum industry

The Quantum Economic Development Consortium (QED-C®) is the world's premier association of pioneers in the quantum technology marketplace. Members of QED-C enable the real-world application of quantum technology, and, in turn, grow a robust commercial industry and supply chain.

[JOIN QED-C](#)

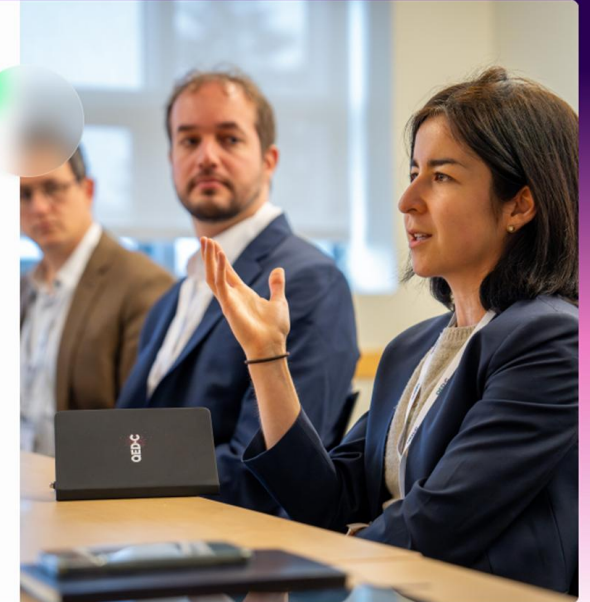

<https://quantumconsortium.org/>

CONCLUSIONS (last sentence)

We advocate that the U.S. maintain a presence in the field and in particular support development of hybrid solutions integrating both PQC and QKD for the greatest protection from threats posed by future quantum computers.

DISCLAIMER

This paper is not a statement or recommendation of policy or any particular position on quantum key distribution by QED-C itself and may or may not be a policy recommendation or position held by any QED-C member.

UPDATES

2026

<https://csrc.nist.gov/News/2026/recommendation-for-cryptographic-key-generation>

Recommendation for Cryptographic Key Generation | NIST Releases Draft SP 800-133 Revision 3 for Comment

April 17, 2026



The initial public draft (ipd) of NIST Special Publication (SP) 800-133r3 (Revision 3), [Recommendation for Cryptographic Key Generation](#), is available for public comment. This document describes the generation of keys to be managed and used by approved cryptographic algorithms.

Proposed changes in this revision include the following:

- Asymmetric key-pair generation has been expanded to include methods for deriving randomness during key-pair generation.
- Key-pair generation now has options for derivation similar to symmetric keys and new methods for “seed expansion,” which allows for the limited use of SHAKE and deterministic random bit generators (DRBGs).
- Key-encapsulation mechanisms (KEMs) are discussed as a key-establishment option for symmetric key generation, and post-quantum cryptography (PQC) references have been added throughout (e.g., the new PQC signatures).
- Text has been reworded to address random number generation in alignment with SP 800-90C.

Comments are especially requested regarding:

- Hardware security module (HSM) design — How do these requirements align with common practice and existing systems using a root seed/secret value?
- PQC implementations and protocol — How do these requirements fit with storing keys as seeds (e.g., for ML-KEM) and performing hybrid (i.e., combined classical and post-quantum) implementations?

The public comment period will be open through June 16, 2026. See the [publication details](#) for a copy of the draft and instructions for submitting comments.

Created April 16, 2026, Updated April 17, 2026

PARENT PROJECT

See: [Key Management](#)

RELATED TOPICS

Security and Privacy: [key management](#)



2025:
(from 2026 Report)

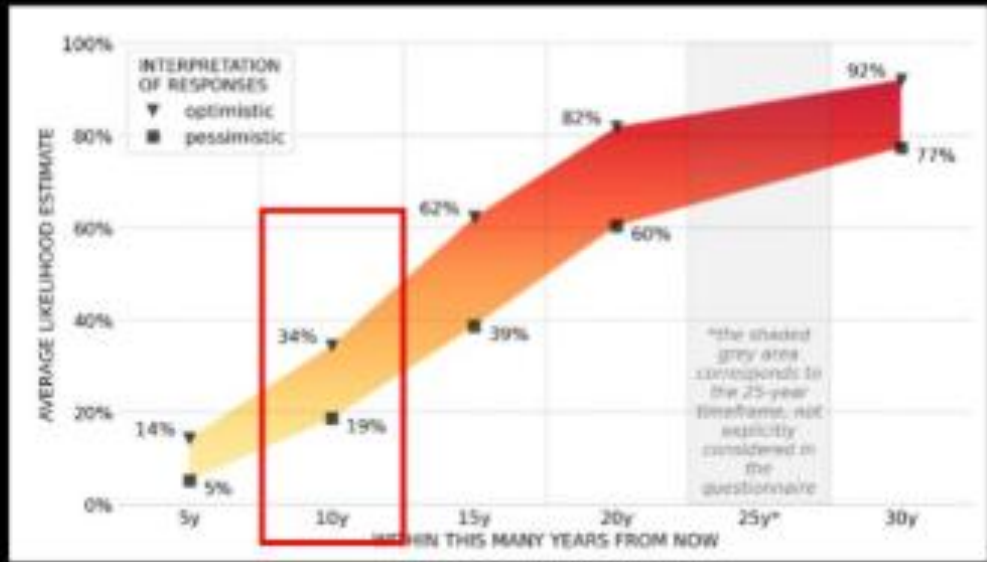
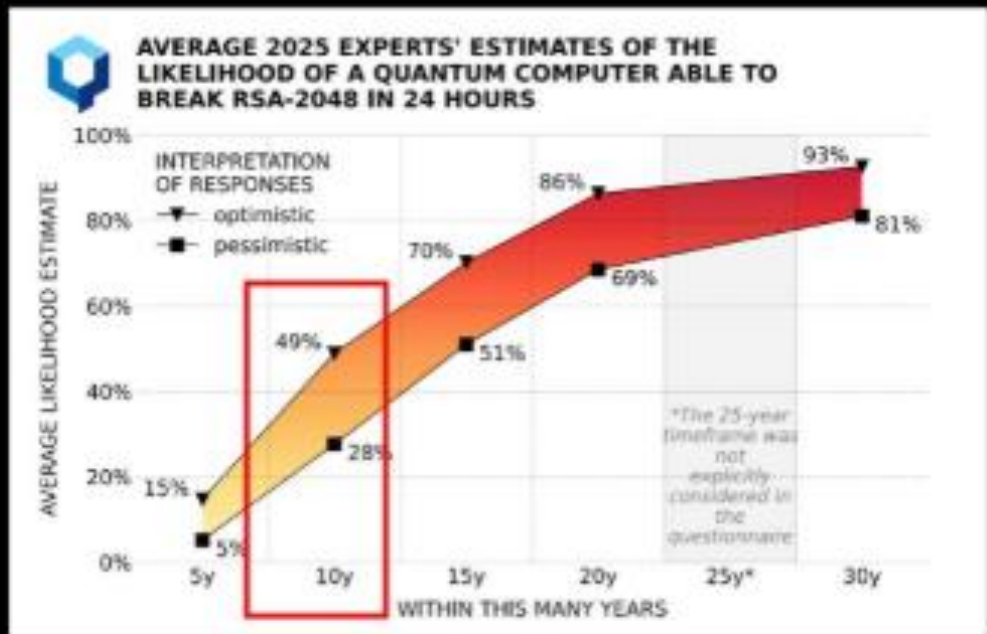

+12pp

2024:
(from 2025 Report)

<https://www.linkedin.com/in/intallura/>

Posted around April 3, 2026



Philip Intallura Ph.D • 1st
Head of Quantum at HSBC | UK Gov Advisor | Board ...
3w •

12 percentage points. One direction.

Quantum Safe can't wait.

In recent weeks alone:

- Fewer than 500k physical qubits can break the encryption protecting Bitcoin and Ethereum.
<https://lnkd.in/eHYpevfC>
- 10,000 neutral atom qubits shown sufficient to break RSA-2048.
https://lnkd.in/e4GN_fhQ
- Google moved their cryptography migration deadline to 2029.
<https://lnkd.in/ex2JmH7M>
- The Quantum Threat Timeline report increased the likelihood of breaking break RSA-2048 by 12 percentage points in a single year.
<https://lnkd.in/egBpE75J>

None of these results are peer-reviewed, but they come from credible institutions and serious researchers.

The pattern is clear: attacks only get better. Progress is rarely linear, and there will be setbacks. But the direction of travel is not in doubt.

Start Now. Or Explain Why You Didn't.



PQC ALONE IS NOT ENOUGH.

YOU NEED QUANTUM-RESILIENT SYSTEMS.

Post-quantum cryptography protects against future decryption. It does not stop what happens now.

INCOMPLETE PROTECTION



PQC ONLY
Future decryption risk addressed

COMPLETE PROTECTION



QUANTUM-RESILIENT SYSTEMS
Protected now and ready for the future

- | | |
|-------------------------|---------------------|
| Real-time interception | Intercept-resistant |
| Data manipulation | Tamper-detected |
| State-level adversaries | Resilient by design |

HYBRID SECURITY. REAL-WORLD PROTECTION.

 PQC RESILIENCE Post-quantum cryptography to secure data against future decryption threats.	+	 QKD SECURE KEY EXCHANGE Quantum Key Distribution to eliminate interception risk at the physical layer.	+	 AI-DRIVEN MONITORING Adaptive, intelligent monitoring to detect anomalies and neutralize threats in real time.
--	---	--	---	--

THE SHIFT IS SIMPLE:
FROM **QUANTUM-RESISTANT** TO **QUANTUM-RESILIENT**.

- | | | |
|--------------------|---------------------|--------------------------|
| REAL THREATS TODAY | REAL PROTECTION NOW | REAL CONFIDENCE TOMORROW |
|--------------------|---------------------|--------------------------|

NOT THEORY. DEPLOYABLE ARCHITECTURE.
We combine cutting-edge technologies and partner expertise to deliver security that stands up to today's and tomorrow's threats.

We're working with partners on real deployments.
Happy to explore where this fits.



Steve H. • 1st
CEO & CISO @ Blackhills Quantum | Securing ...
11h •

May 3, 2026

Post-quantum cryptography solves one problem:

Future decryption.

It does not solve:

- 👉 real-time interception risk

That's where most strategies are incomplete.

Because in high-value environments, "store now, decrypt later" is only half the story.

The other half is:

- interception
- manipulation ...more

Steve H. and 4 others 2 comments

- Like
- Comment
- Repost
- Send

Add a comment...

Most relevant ▾

Blackhills Quantum (BQCM) 10h ...
609 followers

Exactly. PQC is necessary but not sufficient. Resilience requires layered protection: cryptography, key exchange, monitoring, detection and adaptive response working together.

Like | Reply · 1 reply

How Close are Cryptographically Relevant Quantum Computers?

Hsin-Yuan Huang (Robert)

Chief Technology Officer, Oratomic
Assistant Professor of Theoretical Physics, Caltech



What is CRQC?

- ❖ **Cryptographically Relevant Quantum Computers (CRQC)** are futuristic quantum computers that can break **public-key cryptography** by running Shor's algorithm at scale.

Given N find p, q
s.t., $p \times q = N$

RSA-2048

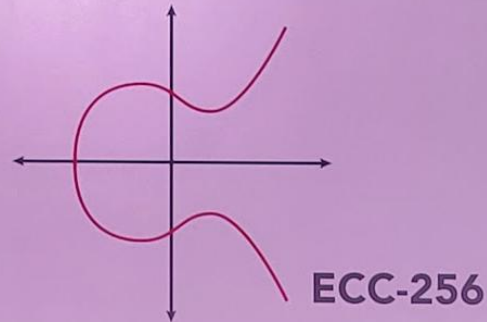

Danger of CRQC

- ❖ Decentralized Finance (**BTC**, ETH, USDC, USDT, RWA):



~1.5 Trillion Market Cap

How Close is CRQC?

- ❖ 2010: **500 million** qubits (theory), **< 20** qubits (experiment).
- ❖ 2018: **20 million** qubits (theory), **< 200** qubits (experiment).
- ❖ 2026: **< 14,000** qubits (theory), **> 6000** qubits (experiment).
- ❖ 2028: ??????????

After CRQC



User data, internet data,
sensor data, financial data,
consumer data, market data, ...

Classical
Data
Samples

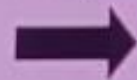

Tiny
Quantum AI

v.s.



Massive
Classical AI

Data Science and ML:

Tiny quantum AI

that can learn and
predict better than

massive classical AI.



THE QUANTUM INTERNET IS TAKING SHAPE



APRIL 14, 2026

IonQ demonstrated entanglement across two separate trapped-ion quantum computers using photons



APRIL 23, 2026

Cisco unveiled a **Universal Quantum Switch**. It translates between all major quantum encoding "languages" at room temperature

Ron Chiarello, PhD
Physicist · Deep-Tech Builder
· Capital Translator, AI ·

<https://outshift.cisco.com/quantum>

Unveiling Cisco's Universal Switch Chip

Enable scalable quantum networking with a switch that preserves quantum information while performing entanglement routing, operates at room temperature over standard telecom fiber, and supports all major quantum computing modalities.

[Learn more](#)





Cisco Research



Quantum Labs

Cisco Universal Quantum Switch explained



LIVE WEBINAR

Scaling the quantum future: Introducing the Cisco Universal Quantum Switch

Join our live session to learn about the first universal quantum switch prototype that operates at room temperature over standard fiber.

Register Now →



The banner features the 'outshift by CISCO' logo on the left. To its right is a white box with a speaker icon and the text 'FREE LIVE WEBINAR'. Below the logo is the title 'Scaling the quantum future: Introducing the Cisco Universal Quantum Switch' in blue text. Underneath the title is the date and time: 'THURSDAY, MAY 28, 2026 · 10 AM PDT'. At the bottom left is a white button that says 'Register today'. On the right side of the banner is a circular portrait of Reza Nejabati, a man with glasses wearing a blue suit jacket over a light blue shirt. Below his portrait is his name 'Reza Nejabati' and his title 'Head of Quantum Research & Quantum Labs, Cisco'.

<https://research.cisco.com/quantum/cisco-universal-quantum-switch>



Qunnect and Cisco Demonstrate First Metro-Scale, High-Speed Quantum Entanglement Swapping Over Commercial Fiber

February 18, 2026

From the lab to the city grid: Qunnect and Cisco demonstrate scalable quantum entanglement networking on existing NYC Fiber

<https://outshift.cisco.com/blog/quantum/scalable-quantum-entanglement-networking>

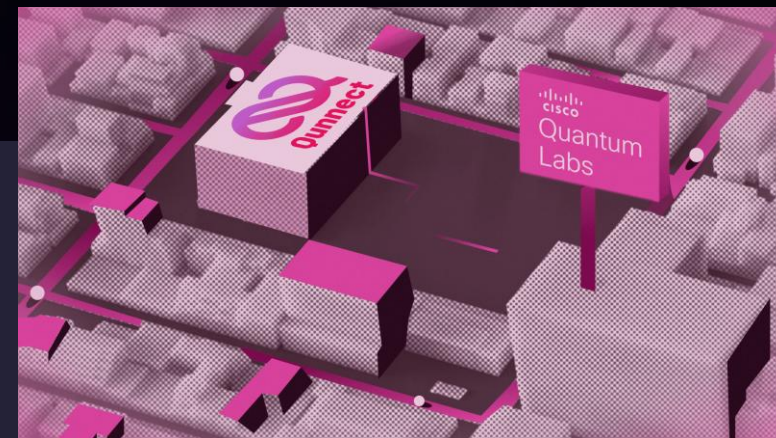

New York QTD Data Center for the Digital Transformation

We make deployments in New York City simpler, faster and more cost effective from one of the most connected buildings in the world.



(left) 60 Hudson, home of QTD Systems. (middle) GothamQ map with the new 16km link to QTD Systems. (right) Building 77 at Brooklyn Navy Yard, home of GothamQ hub



Industry Use Cases

ABQ-Net serves multiple industries, each with distinct needs that quantum networking:

Quantum/Tech	Telecom	Defense	Energy	Financial Services
Quantum research, protocol development and operational testing	Quantum repeater development and next-gen secure telecom networks	Mission sensitive comms, navigation, C2, and sensor networks	Advanced grid security, precision timing, predictive load balancing	Ultra-secure interbank anti-spoofing, intruder alarming
Algorithm verification & test on real world infrastructure	Quantum clock synchronization for 5G/6G networks	Quantum radar and long-baseline sensing	Quantum-enhanced monitoring of critical infrastructure	Quantum random number generation for cryptography

secure comms protocol development

quantum-enhanced timing signals

sensors for navigation, geology, and defense

distributed quantum computing

quantum internet protocols



Mehdi Namazi
Co-founder and Chief Science Officer at Qunnect Inc.





epb
Quantum CenterSM



EPB and IonQ Partner to Establish Chattanooga as the First Quantum Computing and Networking Hub in the U.S.

EPB Quantum in the News

06 April 2026

06 March 2026

02 February 2026

10 December 2025



**Understanding Quantum
Networking ...**

[Learn more](#)



**Inside Tennessee's Growing
Quantum Ecosystem ...**

[Learn more](#)



**EPB awarded \$4 million
federal grant to boost ...**

[Learn more](#)



**EPB and Vanderbilt University
launch innovation institute ...**

[Learn more](#)

<https://epb.com/newsroom/epb-news/understanding-quantum-networking/>

<https://epb.com/newsroom/epb-news/inside-tennessees-growing-quantum-ecosystem/>

<https://epb.com/newsroom/press-releases/epb-awarded-4-million-federal-grant-quantum/>

<https://epb.com/newsroom/press-releases/2025-institute-for-quantum-innovation/>

EPB Quantum
Network[®]



Established in 1997, the Corporation for Education Network Initiatives in California (CENIC) operates the [California Research and Education Network \(CalREN\)](#), a high-capacity computer network with more than 8,000 miles of optical fiber.

Member Endpoint Connections California Research and Education Network (CalREN)

- UC University of California
 - Ag. & Natural Resources
 - Aggregated Sites
- CSU California State Universities
 - Aggregated Sites
- CCC California Community Colleges
 - Aggregated Sites
- Independent Universities
- California K-12 Node Sites
 - Connected via District or COE
- Public Library Jurisdictions
 - Library Branch Sites
- Tribal Nation Connections
- Hospital & Specialized Medical Insts
- Research, Ed. & Cultural Insts



CENIC connects California to the world — advancing education and research statewide by providing a world-class network essential for innovation, collaboration, and economic growth.



Public Quantum Network

*Where everyone can
play with quantum particles.
Come explore with us!*



The Public Quantum Network is supported in part by [NSF Quantum Leap Challenge Institute HQAN under Award No. 2016136](#), [Illinois Computes](#), and by the [DOE Grant No. 712869, "Advanced Quantum Networks for Science Discovery."](#)

Any opinions, findings, and conclusions or recommendations expressed in this material are those of the author(s) and do not necessarily reflect the views of the National Science Foundation.

LOOMIS LABORATORY



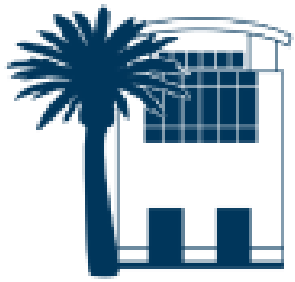

NEWPORT BEACH
PUBLIC LIBRARY

Eddleman Quantum Institute
University of California, Irvine



**We can set this up here !!
And other places too.**

UCI Beall
Applied Innovation



Optical fiber -- same type of
fiber as carries the internet



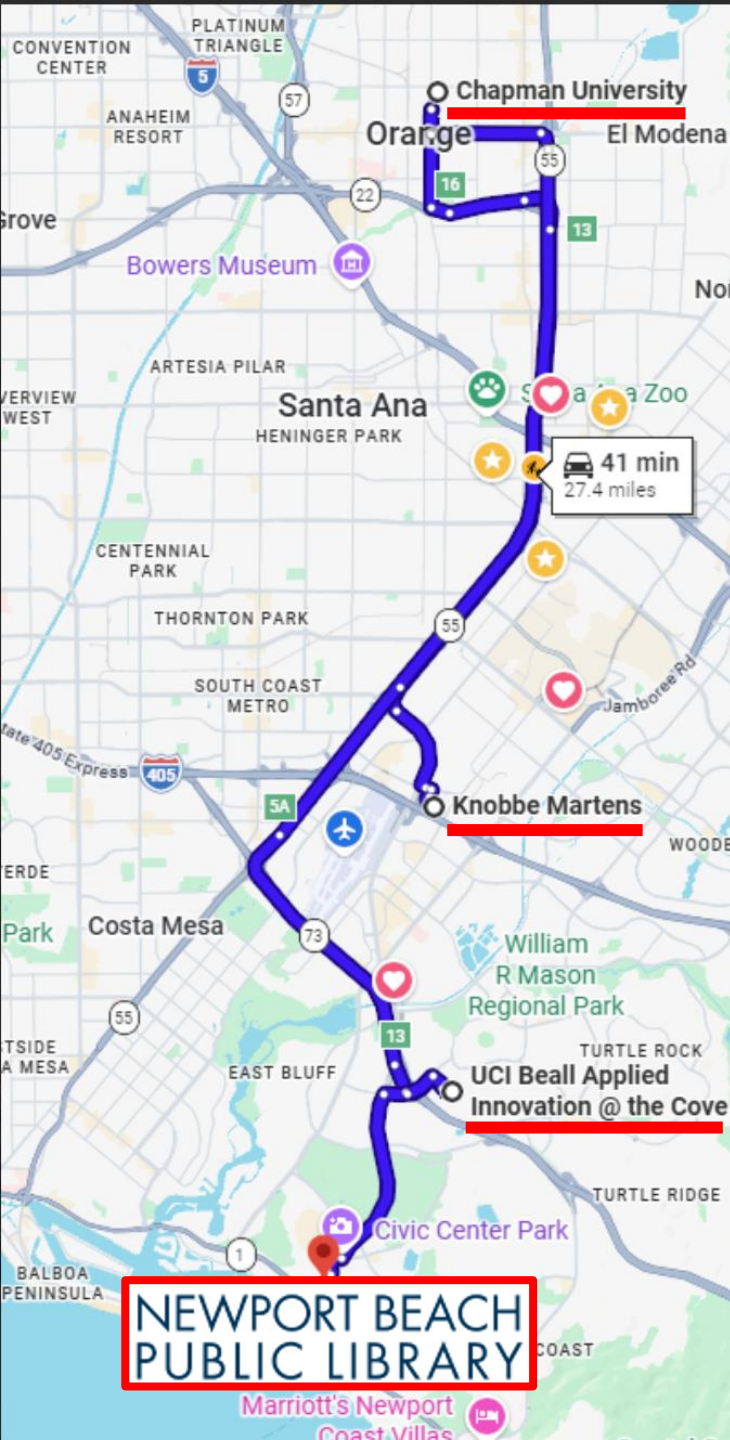

Public Quantum Network

Educational & Research Facility



Quantum Orange County
Coming soon

Daylight Quantum Key Distribution in a Free-Space Channel Using Entangled Photons Emitted by a Quantum Dot Device

F. B. Basset

M. Valeri

+13 authors

R. Trotta

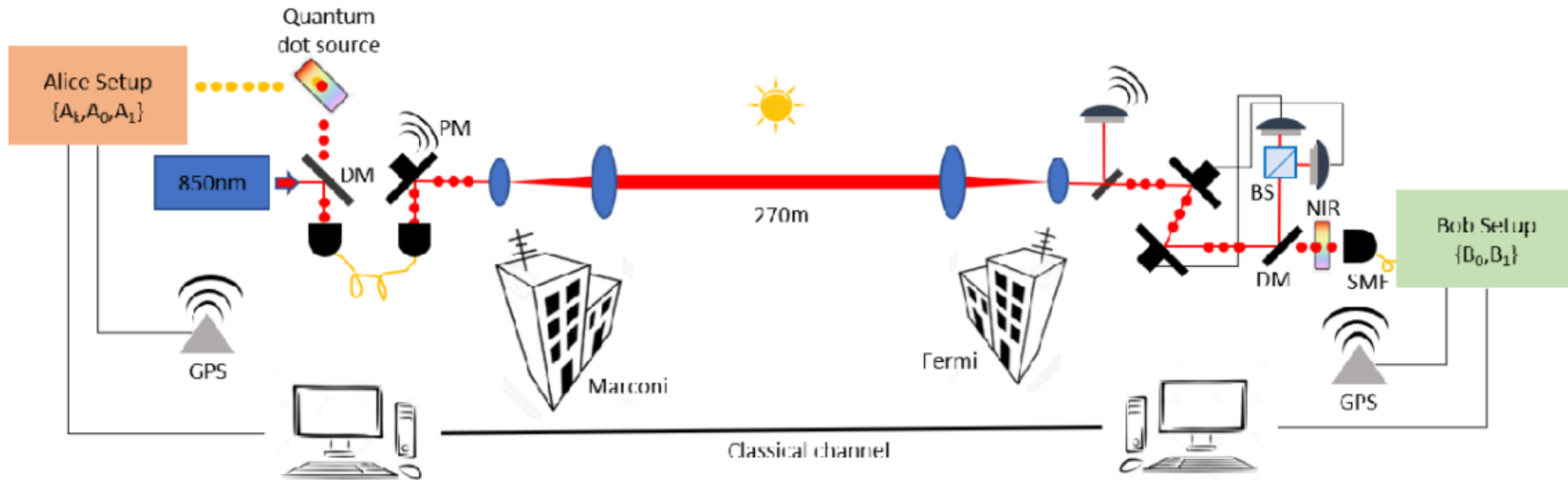
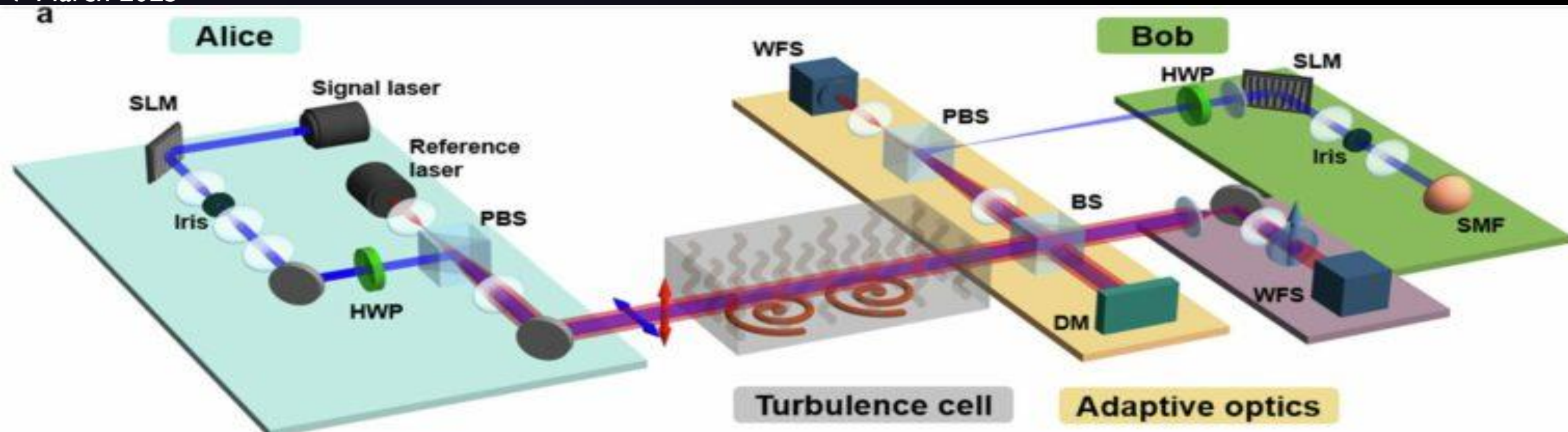

Figure 1: Experimental apparatus. Alice and Bob are placed in two different buildings linked by a free-space optical channel. Pair of entangled photons in polarization are emitted by a quantum dot source in Bob building and prepared in the state $|\varphi^+\rangle = \frac{1}{\sqrt{2}}(|H,H\rangle + |V,V\rangle)$, where H (V) indicates the horizontal (vertical) polarization. One photon is received by Bob apparatus, while the other photon is sent through the air link to the Alice station. Here, the photon is coupled into single-mode fiber (SMF) and measured according to the QKD protocol implemented [2]. 50:50 beam splitters (BS); dichroic mirror (DM); drive mirror with piezoelectric adjuster (PM); narrow spectral filter (NIR). [Collapse](#)

AI and adaptive optics propel free-space quantum communication by solving atmospheric turbulence challenges

7 March 2025



Professor Ebrahim Karimi, the director of Nexus for Quantum Technologies, in collaboration with the National Research Council Canada (NRC) and the Max Planck Institute for the Science of Light (Germany), Now at Chapman University, Institute of Quantum Studies.

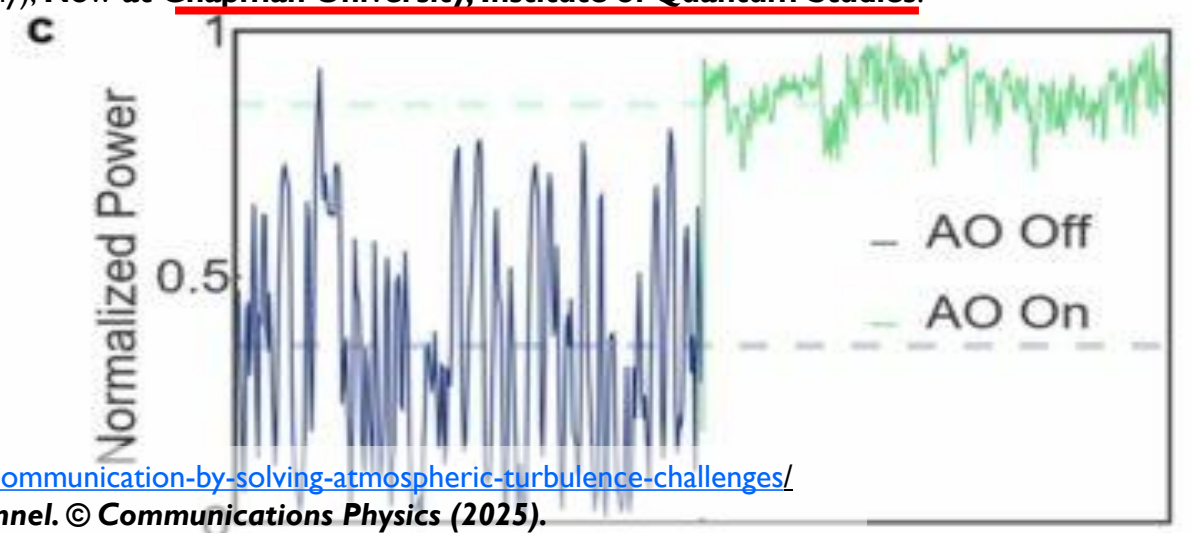

<https://techandsciencepost.com/news/physics/ai-and-adaptive-optics-propel-free-space-quantum-communication-by-solving-atmospheric-turbulence-challenges/>

High-dimensional quantum communication with adaptive optics through a turbulent channel. © Communications Physics (2025).

DOI: 10.1038/s42005-025-01986-6

L3Harris Mission Roadmap for a Quantum Ecosystem

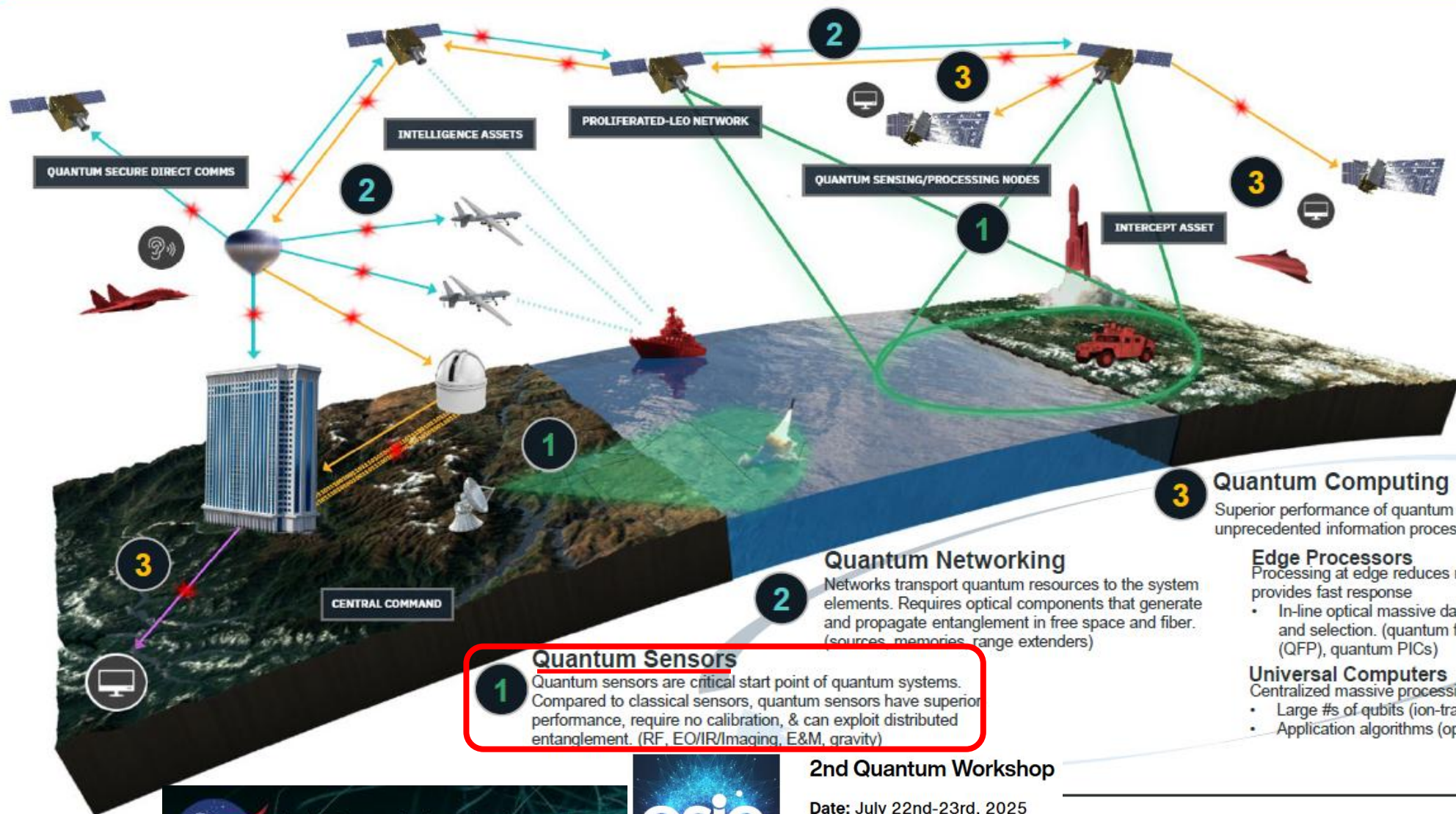

NON-EXPORT CONTROLLED
 THESE ITEM(S) / DATA HAVE BEEN REVIEWED IN ACCORDANCE WITH THE INTERNATIONAL TRAFFIC IN ARMS REGULATIONS (ITAR), 22 CFR PART 120.11, AND THE EXPORT ADMINISTRATION REGULATIONS (EAR), 15 CFR 734(3)(b)(3), AND MAY BE RELEASED WITHOUT EXPORT RESTRICTIONS.

1 Quantum Sensors
 Quantum sensors are critical start point of quantum systems. Compared to classical sensors, quantum sensors have superior performance, require no calibration, & can exploit distributed entanglement. (RF, EO/IR/Imaging, E&M, gravity)

2 Quantum Networking
 Networks transport quantum resources to the system elements. Requires optical components that generate and propagate entanglement in free space and fiber. (sources, memories, range extenders)

3 Quantum Computing
 Superior performance of quantum computers enables unprecedented information processing and system control

- Edge Processors**
 Processing at edge reduces network loading & provides fast response
- In-line optical massive data processing, filtering, and selection. (quantum frequency processor (QFP), quantum PICs)
- Universal Computers**
 Centralized massive processing and system control
- Large #s of qubits (ion-trap, superconducting, photonic)
 - Application algorithms (optimization, crypto, factoring, ML)

Actionable Information



2nd Quantum Workshop
 Date: July 22nd-23rd, 2025
 Location: Caltech

Lots of Quantum Sensors

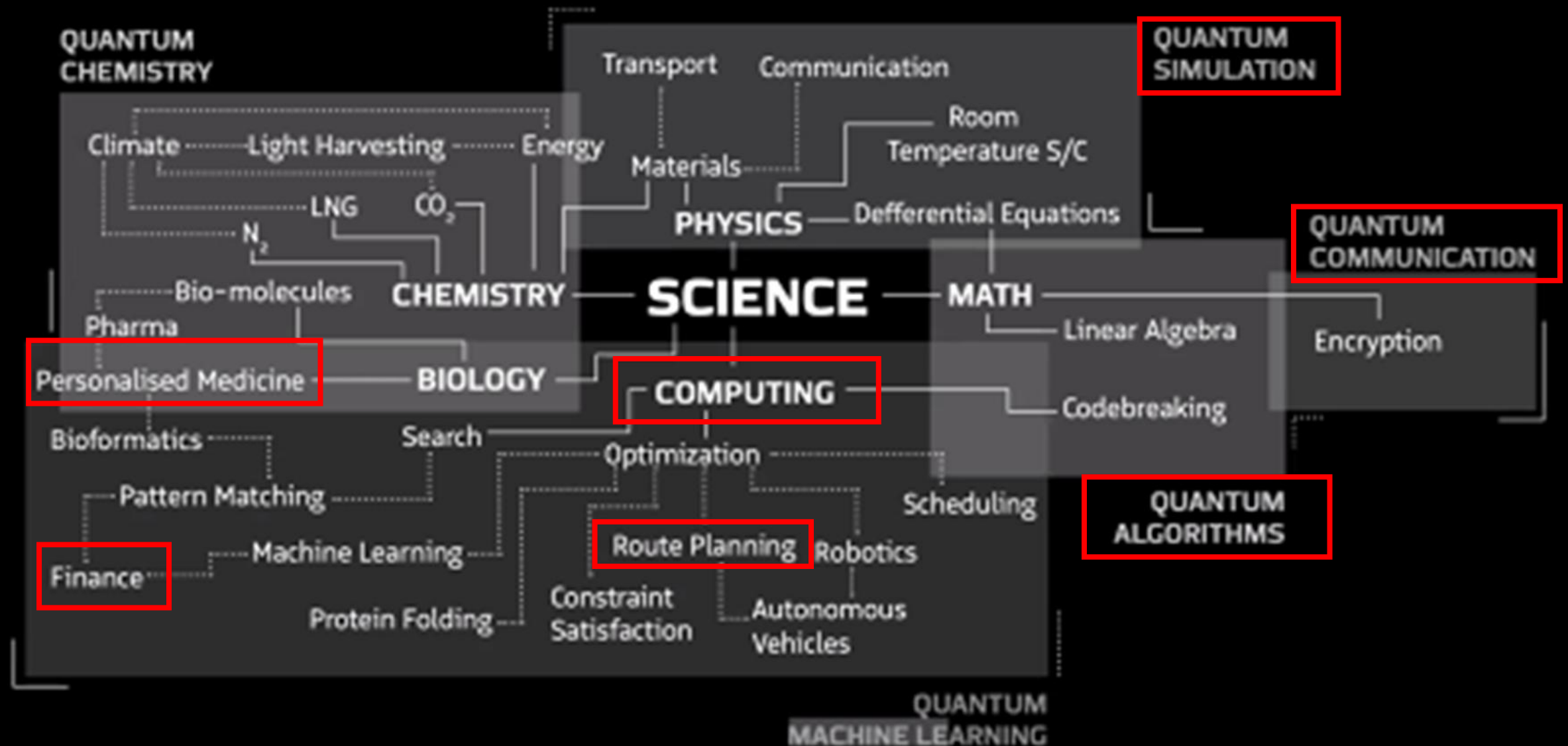

The Daily Qubit

1. [Quantum computing use cases for financial services | IBM](#)
2. [The Future of Quantum Drug Discovery - Cambridge Quantum](#)
3. [Quantum computer models a chemical reaction \(scitation.org\)](#)
4. [Quantum Computing: Accelerating the Digitization of Chemistry • EFMaterials Blog](#)
5. [Quantum Computing in Oil and Gas | Accenture](#)
6. [Inside Google's Quantum Computing Data Center](#)
7. [Quantum ML - Quantum: Machine Learning & Analytics](#)
8. [Exploring quantum computing use cases for manufacturing | IBM](#)
9. [University of Arizona Awarded \\$26M to Architect the Quantum Internet](#)

Quantum Educational Resources

Big Tech Quantum Websites

Quantum Computing Companies

Quantum On-Line Resources

Quantum Biology Papers

And much more

1. Financial Services – Investing, transacting
2. Oil & Gas Exploration and distribution
3. Better Batteries
4. Cleaner Fertilization
5. Traffic Optimization
6. Weather Forecasting and Climate Change
7. Improving Solar Panels
8. Quantum Systems Simulations
9. Quantum Sensors

Machine Learning

Quantum ML - Quantum: Machine Learning & Analytics (ml2quantum.com)

Classical Machine Learning - CML

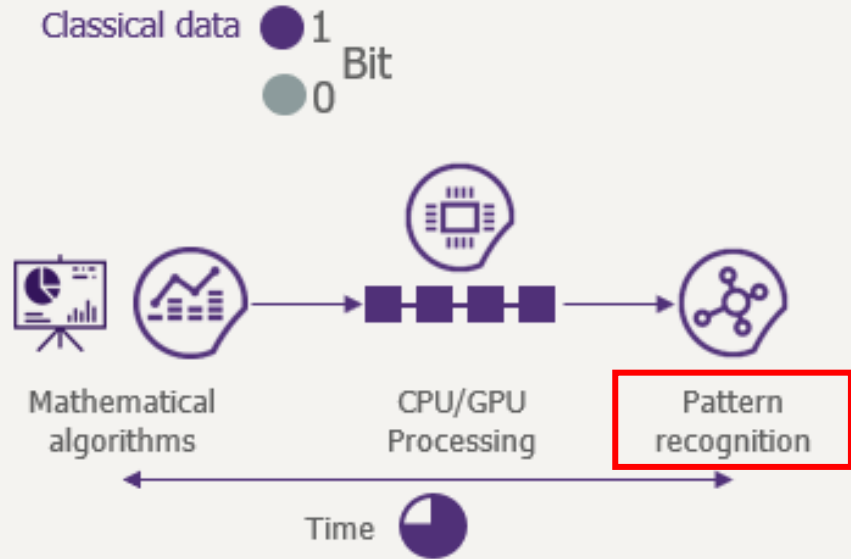

Quantum Machine Learning - QML

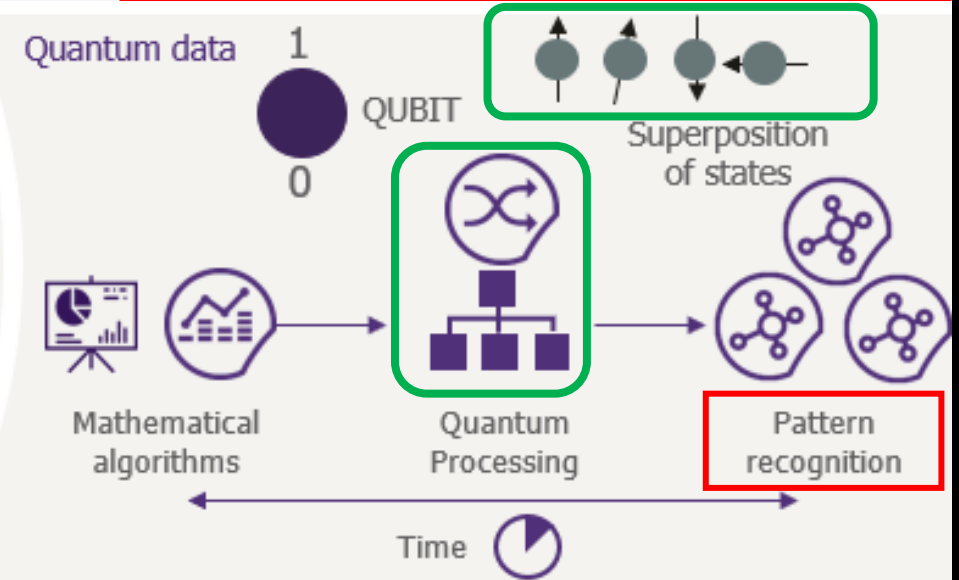

Faster, more efficient, higher accuracy

Processing methods

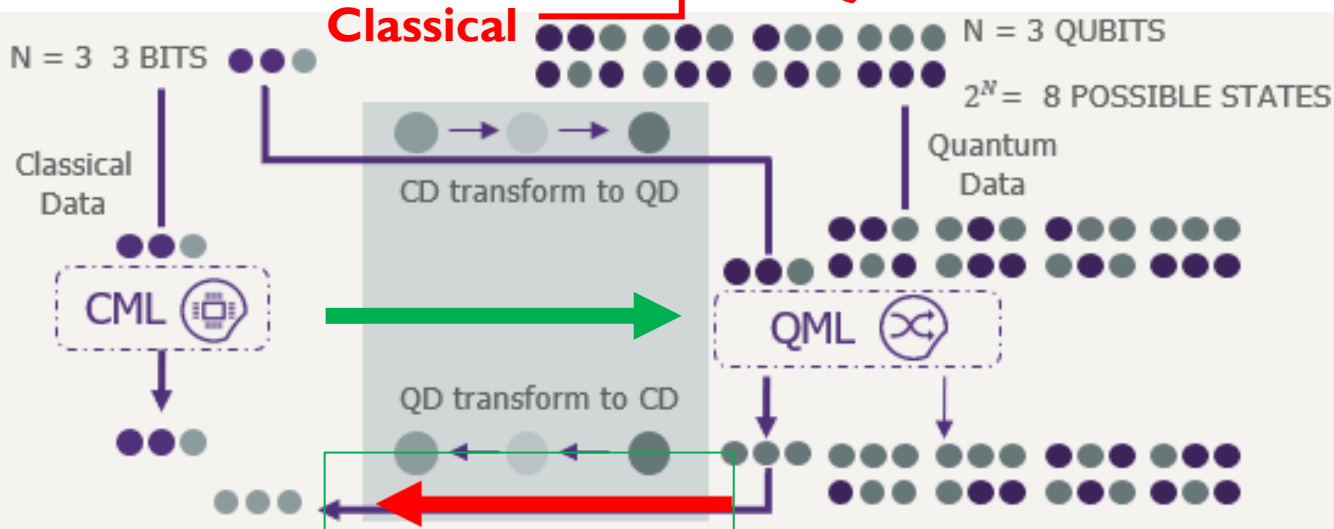

Applications

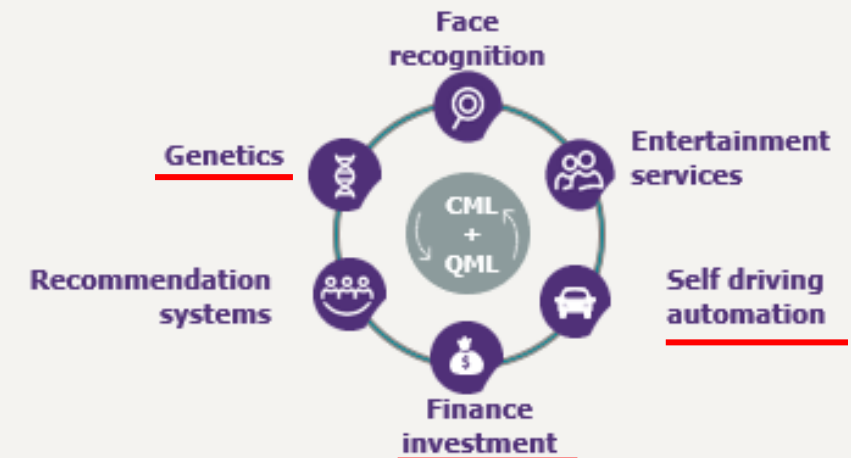

Microsoft, Google, Honeywell, and Amazon

Quantum AI Applications in Manufacturing

30 Jul 2025

6 min read

Quantum AI in the future

Unlocking Efficiency in Industrial Automation

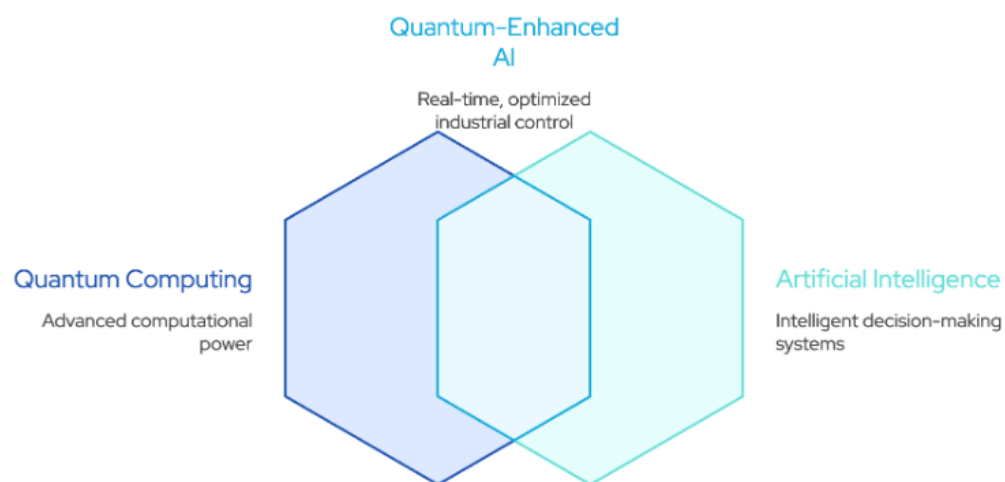

Home | Quantum computing | Exploring quantum computing use cases for manufacturing

Exploring quantum computing use cases for manufacturing

Download the report →

Get free insights via email →

Discover

- Chemistry
- Materials science
- Condensed matter physics

Design

- Finite difference analysis
- Structural analysis
- Hydro/aerodynamics



Manufacturing

Control

- Optimization
- Machine learning
- Classification

Supply

- Supply chain optimization
- Risk modeling

<https://meetiQM.com/blog/quantum-ai-applications-manufacturing/>

Optimizing performance, improving safety, and driving efficiency in manufacturing with Quantum AI applications

[Exploring quantum computing use cases for manufacturing | IBM](#)

Pathways for College Students & Career Professionals

What can you do to get involved with the Quantum World?

1. Be interested
2. Find a Mentor
3. Take Action

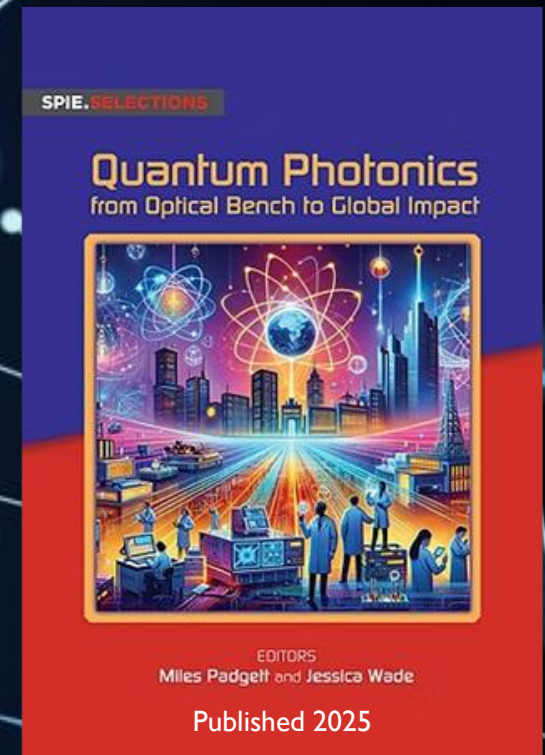

Our SPIE paper "Quantum technician skills and competencies for the emerging Quantum 2.0 industry." was selected and is now available in this book.

Published 2022

Online Resources



The screenshot shows the top navigation bar of the Quantum News & Services website. The menu items are: QOISC HOME, Quantum, Articles, Pubs & Photos, Misc (highlighted with a red box), and Contact. Below the navigation bar is the main content area. On the left is the QOISC logo. In the center is the text 'Life in the QuantumO' and 'The QOISC is a focal point for Doni Quantum Optics Education Ad'. Below this are three blue buttons: 'Teacher Resources', 'Student Resources', and 'Career Assistan'. On the right side, there are several links and logos: 'Quantum News' (with a red box around the text), 'Education & Career Assistance', 'Optics Educational Resources', 'Speakers Submissions' (with 'Alex Small, Ph.D.' below it), 'UC Irvine DCE On-Demand', 'Art & Sci - UCLA', 'Wm. Bickel - Collected sayings', 'Privacy & Use', 'SC Southern California' (with 'website for monthly sch events info.' below it), 'UC Irvine Division of Continuing Education', and 'Workforce Development'.

This webpage has links to websites that offer reliable Quantum News and other services

[McKinsey Quantum Technology Monitor 2026: A commercial tipping point](#)

[The Quantum Economic Development Consortium](#)

[Global Quantum Intelligence](#)

[Quantum Computing Report](#)

[HKA – Marketing Communications](#)

[The Quantum Dragon](#)

[The Quantum Insider](#)

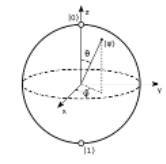

Doug Finke
Chief Content Officer

Sign up here for our *Quantum Computing Report Alerts* email and receive weekly updates on new QC developments.

Established in 2015, the *Quantum Computing Report*, now an offering from *Global Quantum Intelligence (GQI)*, is the most authoritative source for quantum industry developments as they happen. We will chronicle and promote quantum computing developments for parties interested in the industry. We provide news and analysis of technical developments, funding and financing events, partnerships, job opportunities, and much more.

Global Quantum Intelligence publishes market & business intelligences available for a fee to investors, governments, providers, and users to help them navigate through the complex landscape of the quantum industry. For details visit www.global-qi.com.

Print PDF

Recent Posts

- > [Maryland Budget Secures Millions to Consolidate "Capital of Quantum" Status](#)

- > [TreQ Deploys Open-Architecture Quantum Computing Testbed in Oxfordshire, UK](#)

- > [Qruise and Quantum Machines Automate 21-Qubit QPU Bring-Up at IQCC](#)

- > [Qruise and Goethe University Frankfurt Automate NV-Center QPU Bring-Up](#)

- > [Quantum Science Center Researchers Demonstrate First Digital Quantum Simulation of](#)



Hilary Kaye

The First and Only Public Relations Agency Dedicated to the Global Quantum Tech Industry

We generate top-tier media coverage in North America and beyond.

[See Our Clients in the News](#)



Our Clients Have Been Featured In

FORTUNE

nature

MIT
Technology
Review

SCIENTIFIC
AMERICAN

The Quantum spin by hka

Hosted by Veronica Combs

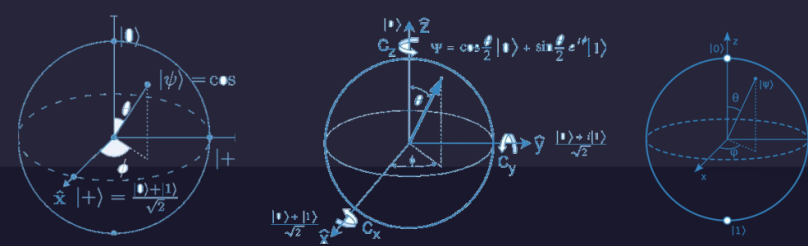

The Quantum spin by hka

HKA WEBINAR SERIES

1 Quantum PR: Build Your Brand, Build Your Business

with Mike Kilroy
HKA Executive VP



Quantum for Students

<https://www.goisc.org/high-school-quantum>

This web page is a resource for students who may have seen my presentation.

[Click here to download a pdf version of the slides.](#) If you would like to give a version of this presentation, contact Donn directly.

These links will be updated periodically.

Video from [National Q-12 Education \(q12education.org\)](http://National Q-12 Education (q12education.org))

Quantum Educational Resources

[Available Courses | qBraid](#)

[DoS - Domain of Science - YouTube](#)

[Map of Quantum Computing Poster – DFTBA](#)

[Qiskit - IBM's Open Source Quantum Computing Resource](#)

[Quantumapalooza 2020 Harrisburg University](#)

[QuVis \(st-andrews.ac.uk\)](#)

[Key Concepts for Future QIS Learners \(illinois.edu\)](#)

[Stanford University - High School Quantum Course](#)

[A Beginner's Guide to Quantum Programming \(scitechdaily.com\)](#)

[Quantum Algorithm Implementations for Beginners](#)

[Schrödinger's Class | Institute for Quantum Computing | University of Waterloo \(uwaterloo.ca\)](#)

(for the Schrödinger's Class materials, contact Donn directly or go to.....)

[Teacher resources | Institute for Quantum Computing | University of Waterloo \(uwaterloo.ca\)](#)

[Quantum Computing for High School Students - text book by Yuly Billing](#)



Get involved with the Quantum World.

1. Find good mentors

1. Start with your Physics Teacher or someone in this room.

2. Take Action:

1. Go to my website, click on links and read articles
2. Watch YouTube videos on Quantum
3. Find hands-on workshops close to home
4. Take on-line courses
5. Go to a college that offers quantum courses
6. Take an internship that works in the field
7. Join a club or start one your self

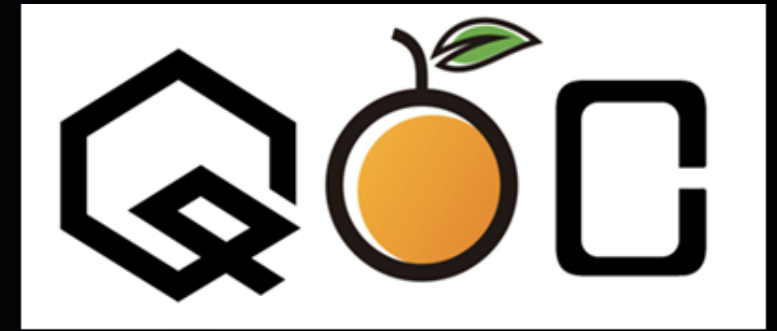

Quantum Orange County

Coming soon

Get Involved Now – Take Action

Three New Quantum Consortia



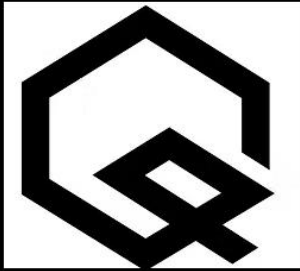

Life in the Quantum Optics Age

The QOISC is a focal point for Donn Silberman's Quantum Optics Education Adventures



Visit the OSSC website for monthly meeting & outreach events info.



UC Irvine
Division of Continuing Education



Follow the Digital White Rabbit
To learn more about:



Contact Us

First Name	Last Name
<input type="text"/>	<input type="text"/>
Email *	
<input type="text"/>	
Write a message	
<input type="text"/>	
<input type="submit" value="Submit"/>	



June 10, 2026
Torrance, CA

Q & A

Things at the Atomic Scale are very different than at the human scale.

Summary

Thank You

Donn Silberman

Quantum Optics Institute of Southern California

<http://qoisc.org>

Donn@qoisc.org

- The Quantum World underlies our modern civilization.
- And Quantum is about take humanity to the next level.
- You can help make it happen.

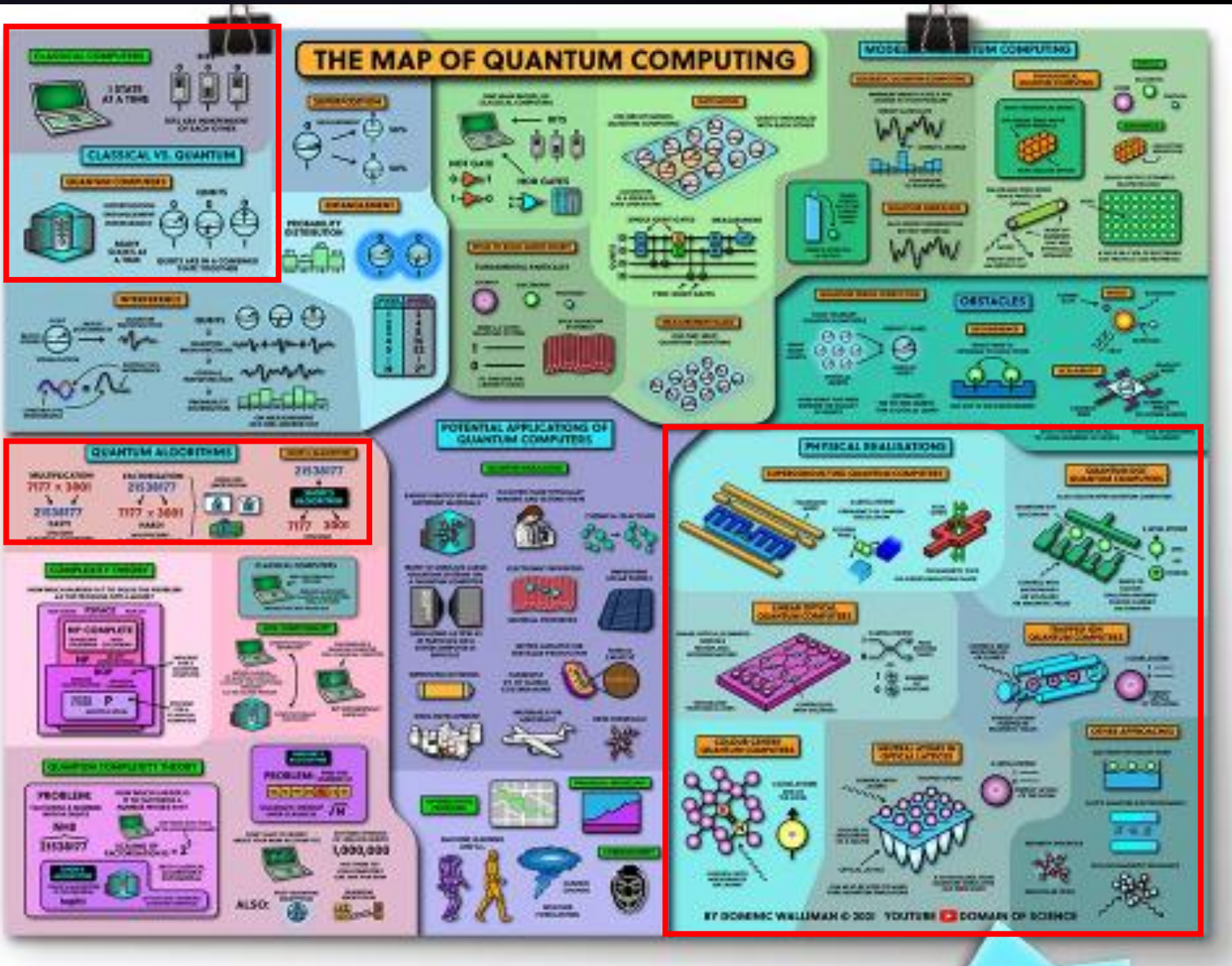

What's new at IBM Quantum? Check out the latest tools, performance improvements, and updates delivered so far this year. [Read the blog](#) →

🌐 Qiskit SDK v2.1 is here

[See what's new](#) →

Qiskit

Qiskit is the world's most popular software stack for quantum computing. Build circuits, leverage Qiskit functions, transpile with AI tools, and execute workloads in an optimized runtime environment.

What is Qiskit? 🎥

[Get started](#) ↗



01 Performance 02 Workflow 03 Tools and services 04 Get started 05 Tutorials 06 Systems 07 Community 08 Qiskit blog

[Qiskit.org](https://qiskit.org)

IBM's Education System – it's FREE